

# Redundancy Switch N:1 RSCM



The WORK Microwave Redundancy Switch System N:1 can be configured for redundancy configurations with maximum 8 main units and one spare unit. The redundancy system can be used for upconverters, downconverters, modulators, modulator-upconverters, LNAs and even HPAs can optionally be protected. The core of the solution is a highly flexible control unit. The required coaxial transfer switches, waveguide transfer switches or signal splitters are mounted on separate panels or within an outdoor housing. At rack mount redundancy systems switching panels can be added in a modular way to the system if the number of required channels increases over time. Also DC power to LNAs can be provided, if required.

The switching system can be set in automatic mode, where an automatic switchover to the spare unit is performed upon detection of an alarm of the main unit. Also a manual switchover to the spare unit and back can be initiated.

Two power supplies and two AC input connectors within the controller unit guarantee very high availability.

The Redundancy Switch System is also available with integrated Uplink Power Control (Option UPC). For functional details see separate datasheet for Uplink Power Control Unit.

The system can be configured from the front panel of the controller or remotely via RS232, RS422/485 or TCP/IP over Ethernet.

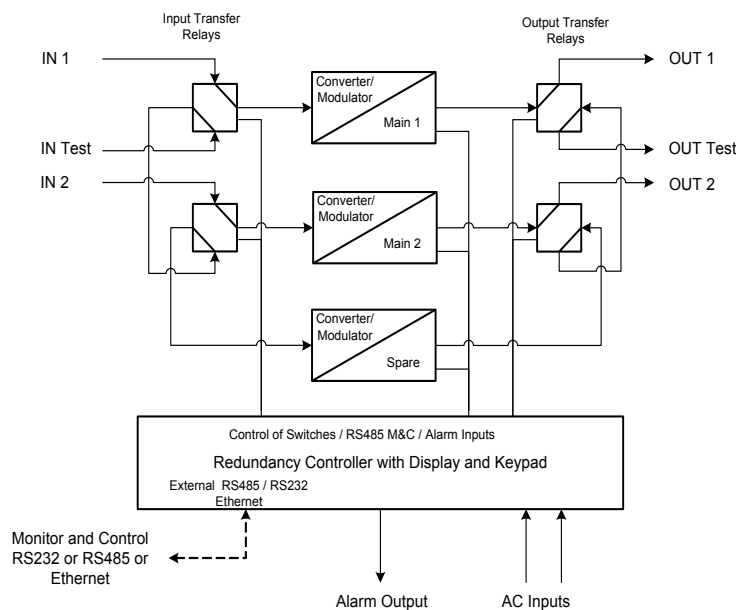

**2:1 Redundancy  
Switch System**

# Outdoor Redundancy Switch Unit 2:1

The Picture shows an outdoor switching unit of a 2:1 redundant switching system. The switching unit is connected to the control unit, which is installed indoor. Within the outdoor switch unit alarm and status indication via LEDs, manual switchover and easy access to the serial control interfaces of the converter units e.g. is possible. The picture below shows a typical 2:1 configuration with upconverters, built as outdoor solution.

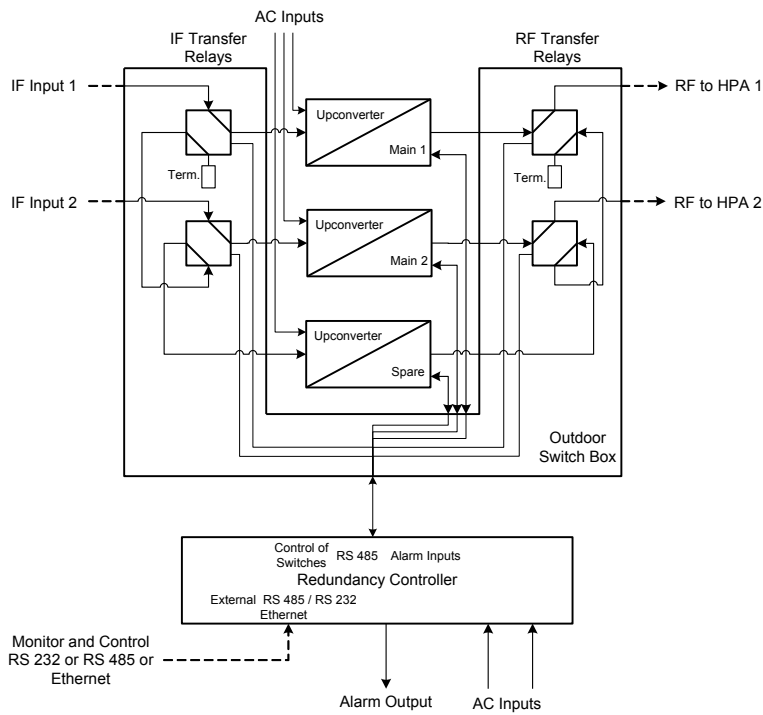

2:1 Redundancy Switch System with Outdoor Switch Unit

# Redundancy Switch System (N:1)

<b>Remote M&amp;C Interface:</b>	Protocol: Connection:	SNMP UDP over Ethernet (10 or 100 Mbps, auto sensing), connector RJ-45
	Protocol: Connection:	HTTP (web browser interface) TCP/IP over Ethernet (10 or 100 Mbps, auto sensing), connector RJ-45
	Protocol: Connection:	Multipoint RS232 or RS422/RS485 (configurable), connector DSUB09 female or TCP/IP over Ethernet (10 or 100 Mbps, auto sensing), connector RJ-45
<b>Maximum number of switches per each switch panel:</b>	4 (Indoor switch panel)	
<b>Signal Transfer Switches (Input and/or Output) RSCM-n-xx-50K RSCM-n-50K-xx</b>	Connector type: Impedance: Power handling: Frequency Range: Insertion Loss:  Isolation:  Return Loss:	4 x SMA female (Indoor switch panel) (N female on IF interfaces, SMA female on RF interfaces of outdoor switch unit) 50 Ω 1 W (switching) 0 ... 18 GHz <0.1 dB (0 ... 1 GHz) <0.2 dB (1 ... 4 GHz) <0.3 dB (4 ... 8 GHz) <0.4 dB (8 ... 12 GHz) <0.5 dB (12 ... 18 GHz) >85 dB (0 ... 1 GHz) >80 dB (1 ... 4 GHz) >70 dB (4 ... 8 GHz) >65 dB (8 ... 12 GHz) >60 dB (12 ... 18 GHz) >26 dB (0 ... 1 GHz) >21 dB (1 ... 4 GHz) >16 dB (4 ... 8 GHz) >15 dB (8 ... 12 GHz) >14 dB (12 ... 18 GHz) (waveguide switches and other transfer switches on request)
<b>Signal Transfer Switches (Input and/or Output) RSCM-n-xx-75L RSCM-n-75L-xx</b>	Connector type: Impedance: Power handling: Frequency Range: Insertion Loss:  Isolation:  Return Loss:	4 x 1.6/5.6 female (Indoor switch panel) (Adapters to external BNC female connectors are provided) 75 Ω 1 W (switching) 0 ... 2.5 GHz <0.2 dB (0 ... 1 GHz) <0.3 dB (1 ... 2.5 GHz) >80 dB (0 ... 1 GHz) >70 dB (1 ... 2.5 GHz) >20 dB (0 ... 1 GHz) >18 dB (1 ... 2.5 GHz)
<b>Temperature Range:</b>	-30°C ... 60°C operating -25°C ... 60°C operating (for RSCM-n-L75T..) (the LCD display is operational: -20°C ... 60°C) -30°C ... 80°C storage	
<b>Relative Humidity:</b>	<95% non condensing	
<b>User Interface:</b>	LCD, 2 x 40 characters, 4 cursor keys, 2 function keys	
<b>Mains Power Input:</b>	2 x 100 ... 240 V AC nominal, 90...264 V AC max, 50...60 Hz, Redundant Power Supply, Hot swap	
<b>Mains Power Consumption:</b>	Max: 16 VA / 8 W Typ: 10 VA / 5 W	
<b>Mains Power Input Connector:</b>	2 x IEC C14	
<b>Mains Fuse:</b>	2 x 2 x 2.0 A time-lag fuse	
<b>Dimension and Weight of Redundancy Controller:</b>	483 x 44 x 270 mm <sup>3</sup> (WxHxD), 1 RU (19") approx. 4 kg	
<b>Dimension and Weight of Outdoor Redundancy Switch Unit 2:1:</b>	300 x 150 x 400 mm <sup>3</sup> (WxHxD) approx. 7 kg	

Specifications are subject to change

**Order Information:**

**RSCM-[Number of signal channels]-[Input Switch Type]-[Output Switch Type]-  
[Options]**

**Possible Options are:** **OD** (with outdoor switch unit, available only for two channels)  
**UPC** (Uplink Power control included)  
**AO** (Internal Alarm only connection, without RS485 communication)

**Examples:**

**RSCM-2-50K-50K**  
**RSCM-2-50K-50K-OD**  
**RSCM-8-50K-50K**