

SATCOM
Technologies

Satellite
IF Up-/Down-
Converters

Satellite
Block
Converters

03/2012

Redundancy
Switches
1:1 / N:1

and more

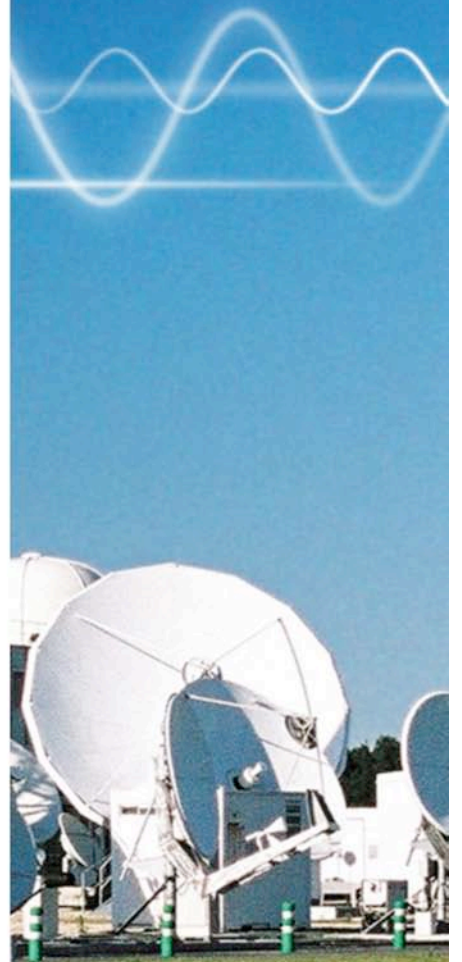

Table of Contents

Page

Satellite Up- and Downconverter	3
Satellite Up- and Downconverter, Outdoor Version	13
Dual Channel, Shared Oscillator Downconverter	19
Inmarsat Downconverter.....	22
Narrowband Downconverter.....	22
Synthesized Block Up- and Downconverter	27
Synthesized Block Up- and Downconverter Outdoor Version.....	34
L-Band Block Upconverter	38
L-Band Block Downconverter	41
Narrowband Block Downconverter.....	44
Satellite Block-Upconverter (mini-buc).....	45
Satellite Block-Upconverter (mini-buc).....	46
Block-Converter Reference Module	49
Remote Control Unit	50
Satellite Uplink Power Control Unit	50
Automatic Level Control (ALC) Filter Amplifier	52
Automatic Level Control (ALC) Filter Amplifier	53
Redundancy Switch 1:1	55
Redundancy Switch 1:1 for IP Modem	59
Redundancy Switch N:1	62
Outdoor Housings.....	66

Satellite Up- and Downconverter

Single / Dual / Triple Band
 Single / Dual Channel
 S-, C-, X-, Ku-, K(DBS)-, Ka-Band



The satellite up- and downconverters which are developed and manufactured by WORK Microwave, are designed to satisfy the high requirements of modern satellite transmission, such as TV uplinks and high speed data networks. Analogue transmission formats are supported as well as digital transmission formats. For many years, these devices have been used worldwide for fixed satellite earth stations, satellite news gathering (SNG) vehicles and other mobile or portable applications. The up- and downconverters have been produced more than 1200 times so far and customers worldwide appreciate their reliability and high level of quality.

4th Generation – still better

The 4th generation, based on our experience and skill, is still better. The synthesizer and oscillator portion in every satellite converter is the most important component because it decides the converter's reliability. For many years WORK Microwave has been developing and manufacturing high sophisticated microwave oscillators and synthesizers, which are used in our converter series as well. The new design allows us to reduce the number of components by more than 30%. In addition, significant improvements have been made on circuit design.

This design results in an AC power consumption of typically 35 VA / 23 W. This leads to an even higher reliability and longer life time.

S-, C-, X-, Ku-, K and Ka-Band coverage

The satellite converter series cover the satellite frequency bands S-, C-, X-, Ku-, K- and Ka-Band. The converters support the standard IF-frequency bands 70 ± 20 MHz and/or 140 ± 40 MHz. The conversion is performed without spectral inversion. The upconverters offer an increased power output ($P_{1dB} \geq +10$ dBm) in all versions. The units are available as single band, dual band or as triple band converters (see also next page under "Specials and OEM products").

High signal integrity

The extreme low phase noise of the oscillators guarantees an excellent signal quality. Low spurious emissions allow our customers to use the converters also in the environments with demanding requirements, such as high power video uplinks. Sophisticated temperature compensation guarantees the stability over a very wide temperature range.

Housing options

The converters normally are delivered without fans and can be operated in environments, where at minimum 1 RU space for natural ventilation is available above each unit. This eliminates the fan as potential point of failure. For rack installations without any space in between the units a fan within the converter unit is recommended, which forces an airflow from the right side to left side of the units.

Operating and control – easy integration into your system

The converters can be operated via the push buttons on the front panel using self-explanatory display menus or via remote control (RS232, RS422/485, TCP/IP over Ethernet). Detailed monitoring of the system status and a summary alarm output (dual change over switch contacts) are provided. For the remote control either ASCII string based commands as well as addressable, packet based commands are provided.

Remote monitoring and control through SNMP and a Web browser interface is also available.

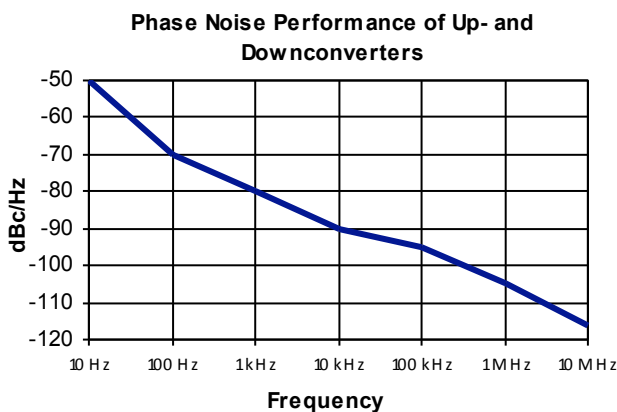

Customized products

In addition to standard products WORK Microwave offers custom tailored products and specialized products as follows:

- Modified or smaller housings to fit into your existing design for mobile and portable applications.
- Extended storage or operating temperature range.
- Military versions for hostile environment (shock, vibration, humidity).
- For downconverters: Application specific output filtering and automatic level control. The output level is kept constant independent of the strength of the input signal with adjustable control.
- Additional PLO output.

Key features

- 70 MHz or 140 MHz IF bands available
- Optional switchable IF 70 MHz and 140 MHz (IF 70/140)

- Extreme low power consumption maximum 38 VA / 25 W (single band unit) 40 VA / 27 W (triple band units)
- Extreme low phase noise (< -50 dBc/Hz @ 10 Hz)
- Long- term stability 10^{-7} / year
- Output power +10 dBm (1 dB compression point)
- Low spurious emissions < -80 dBm at full gain (high performance series)
- Automatic reference recognition (5 and 10 MHz)
- Adjustable gain equalizer
- Digital gain compensation
- Operating temperature range either -30°C to 60°C (-22°F to 140°F) or 0°C to 50°C (32°F to 122°F)
- Remote control through RS232, RS422/485 (2-wire or 4-wire) interfaces. Packet command syntax supports RS485 bus systems and allows addressed operation.
- Remote control through Ethernet supporting a TCP/IP command interface, a Web browser interface and SNMP (MIBs are provided).
- Test output on the front panel: RF-Test at upconverter, IF-Test at downconverter.
- Optional IF-Test output for upconverters on rear panel (Option: IFT)
- AC power switch on the front panel
- Summary alarm output (dual change over switch contacts)
- Transmit mute input
- Optional internal Fan (Option: FAN)
- CE compliant
- **3 years warranty**

Order information

WORK Microwave offers two series of 19" rack mount satellite converters, Standard and High Performance. The specifications are the same for both types except the operating temperature range. The High Performance type operates between -30°C to 60°C (-22°F to 140°F) and the Standard type between 0°C to 50°C (32°F to 122°F). So if you only need units for inside use, the standard unit is perfectly suited for this application.

Open questions, demo units

If you need more information about WORK Microwave's 4th satellite converter generation or if you would like to have demo unit, please contact us via e-mail: sales@work-microwave.de or call us. We are glad to assist you.

Satellite Upconverter

Indoor Version

Single / Dual / Triple Band Upconverter or Dual Channel Upconverter
 S-Type (standard version), H-Type (extended temperature range)

Upconverter Type:	HCU-S / SCU-S	HCU-S4 / SCU-S4	HCU-C / SCU-C	HCU-C1 / SCU-C1
RF-Output Frequency:	S-Band 2.025...2.290 GHz	S-Band 2.0...2.6 GHz	C-Band 5.85...6.65 GHz	C-Band 5.85...7.03 GHz
Intermediate Frequency:	2450 MHz for 70 MHz IF Input 2440 MHz for 140 MHz IF Input	3050 MHz for 70 MHz IF Input 3040 MHz for 140 MHz IF Input	2450 MHz for 70 MHz IF Input 2440 MHz for 140 MHz IF Input	2610 MHz for 70 MHz IF Input 2600 MHz for 140 MHz IF Input
Phase Noise:	10 Hz 100 Hz 1 kHz 10 kHz 100 kHz 1 MHz	-60 -80 -90 -98 -103 ¹⁾ -112 ¹⁾	-60 -80 -90 -98 -103 ¹⁾ -112 ¹⁾	-55 -75 -85 -95 -100 ¹⁾ -110 ¹⁾
	max. values in dBc/ Hz ¹⁾ 0°C ... 50°C, outside this temperature range degraded by max 5 dB.			
Test Output: (Fixed Oscillator)	2520 MHz (70 MHz IF) 2580 MHz (140 MHz IF) -6 ± 3 dBm SMA female	3120 MHz (70 MHz IF) 3160 MHz (140 MHz IF) -6 ± 3 dBm SMA female	2520 MHz (70 MHz IF) 2580 MHz (140 MHz IF) -6 ± 3 dBm SMA female	2680 MHz (70 MHz IF) 2740 MHz (140 MHz IF) -6 ± 3 dBm SMA female
Test Output: (Microwave Oscillator)	4.475...4.740 GHz (70 MHz IF) 4.465...4.730 GHz (140 MHz IF) -7 ± 3 dBm SMA female	5.05...5.65 GHz (70 MHz IF) 5.04...5.64 GHz (140 MHz IF) -7 ± 3 dBm SMA female	8.30...9.10 GHz (70 MHz IF) 8.29...9.09 GHz (140 MHz IF) -7 ± 3 dBm ²⁾ SMA female	8.46...9.64 GHz (70 MHz IF) 8.45...9.63 GHz (140 MHz IF) -7 ± 3 dBm ²⁾ SMA female

Upconverter Type:	HCU-X	HCU-Ku / SCU-Ku	HCU-Ku2 / SCU-Ku2	HCU-K / SCU-K
RF-Output Frequency:	X-Band 7.90...8.40 GHz	Ku-Band 12.75...14.50 GHz	Ku-Band 11.80...13.40 GHz	K-Band 17.3...18.4 GHz
Intermediate Frequency:	2450 MHz for 70 MHz IF Input 2440 MHz for 140 MHz IF Input	2450 MHz for 70 MHz IF Input 2440 MHz for 140 MHz IF Input	2300 MHz for 70 MHz IF Input 2270 MHz for 140 MHz IF Input	2450 MHz for 70 MHz IF Input 2440 MHz for 140 MHz IF Input
Phase Noise:	10 Hz 100 Hz 1 kHz 10 kHz 100 kHz 1 MHz	-53 -73 -83 -93 -98 ¹⁾ -108 ¹⁾	-50 -70 -80 -90 -95 ¹⁾ -105 ¹⁾	-50 -70 -80 -90 -95 ¹⁾ -105 ¹⁾
	max. values in dBc/ Hz ¹⁾ 0°C ... 50°C, outside this temperature range degraded by max 5 dB.			
Test Output: (Fixed Oscillator)	2520 MHz (70 MHz IF) 2580 MHz (140 MHz IF) -6 ± 3 dBm SMA female	2520 MHz (70 MHz IF) 2580 MHz (140 MHz IF) -6 ± 3 dBm SMA female	2370 MHz (70 MHz IF) 2410 MHz (140 MHz IF) -6 ± 3 dBm SMA female	2380 MHz (70 MHz IF) 2300 MHz (140MHzIF) -6 ± 3 dBm SMA female
Test Output: (Microwave Oscillator)	10.35...10.85 GHz (70 MHz IF) 10.34...10.84 GHz (140 MHz IF) -7 ± 3 dBm ²⁾ SMA female	15.20...16.95 GHz (70 MHz IF) 15.19...16.94 GHz (140 MHz IF) -7 ± 3 dBm ²⁾ SMA female	14.1...15.7 GHz (70 MHz IF) 14.07...15.67 GHz (140 MHz IF) -7 ± 3 dBm ²⁾ SMA female	14.85...15.95 GHz (70 MHz IF) 15.86...15.96 GHz (140 MHz IF) -7 ± 3 dBm ²⁾ SMA female

Specifications continued next page

²⁾ -12 ± 3 dBm for Dual-Band units and Triple-Band units e.g. HCU3-CXKu, HCU3-CKuK

Satellite Upconverter

Indoor Version

Single / Dual / Triple Band Upconverter or Dual Channel Upconverter S-Type (standard version), H-Type (extended temperature range)

Specifications continued:

Upconverter Type:	HCU-Ka / SCU-Ka	HCU-Ka1 / SCU-Ka1	HCU-Ka3-2 / SCU-Ka3-2	HCU-Ka4 / SCU-Ka4
RF-Output Frequency:	Ka-Band 29.7...31.5 GHz	Ka-Band 19.2...20.2 GHz	Ka-Band 17.7...19.5 GHz 19.4...21.2 GHz (automatically switched)	Ka-Band 27.5...31 GHz
Intermediate Frequency:	2450 MHz for 70 MHz IF Input 2440 MHz for 140 MHz IF Input	2450 MHz for 70 MHz IF Input 2440 MHz for 140 MHz IF Input	2450 MHz for 70 MHz IF Input 2440 MHz for 140 MHz IF Input	5170 MHz for 70 MHz IF Input 5100 MHz for 140 MHz IF Input
Phase Noise:	10 Hz 100 Hz 1 kHz 10 kHz 100 kHz 1 MHz	-46 -66 -76 -86 -88 ¹⁾ -101 ¹⁾	-50 -70 -80 -90 -95 ¹⁾ -105 ¹⁾	-46 -66 -76 -86 -88 ¹⁾ -101 ¹⁾
max. values in dBc/ Hz ¹⁾ 0°C ... 50°C, outside this temperature range degraded by max 5 dB.				
Test Output: (Fixed Oscillator)	2380 MHz (70 MHz IF) 2300 MHz (140MHzIF) -6 ± 3 dBm SMA female	2380 MHz (70 MHz IF) 2300 MHz (140MHzIF) -6 ± 3 dBm SMA female	2380 MHz (70 MHz IF) 2300 MHz (140MHzIF) -6 ± 3 dBm SMA female	5240 MHz (70 MHz IF) 5240 MHz (140MHzIF) -6 ± 3 dBm SMA female
Test Output: (Microwave Oscillator)	27.25...29.05 GHz (70 MHz IF) 27.26...29.06 GHz (140 MHz IF) - 10 ± 3 dBm SMA female	16.75...17.75 GHz (70 MHz IF) 16.76...17.76 GHz (140 MHz IF) - 7 ± 3 dBm SMA female	15.25...18.75 GHz (70 MHz IF) 15.26...18.76 GHz (140 MHz IF) - 7 ± 3 dBm SMA female	16.335...18.085 GHz (70 MHz IF) 16.335...18.085 GHz (140 MHz IF) - 7 ± 3 dBm SMA female

Upconverter Type:	HCU-Ka8 / SCU-Ka8			
RF-Output Frequency:	Ka-Band 22.55...23.15 GHz			
Intermediate Frequency:	2150 MHz for 70 MHz IF Input 2140 MHz for 140 MHz IF Input t			
Phase Noise:	10 Hz 100 Hz 1 kHz 10 kHz 100 kHz 1 MHz	-46 -66 -76 -86 -88 ¹⁾ -101 ¹⁾		
max. values in dBc/ Hz ¹⁾ 0°C ... 50°C, outside this temperature range degraded by max 5 dB.				
Test Output: (Fixed Oscillator)	2080 MHz (70 MHz IF) 2000 MHz (140MHzIF) -6 ± 3 dBm SMA female			
Test Output: (Microwave Oscillator)	10.2...10.5 GHz (70 MHz IF) 10.205...10.505 GHz (140 MHz IF) - 7 ± 3 dBm SMA female			

Specifications continued next page

Satellite Upconverter

Indoor Version

Single / Dual / Triple Band Upconverter or Dual Channel Upconverter S-Type (standard version), H-Type (extended temperature range)

Specifications continued:

Conversion Scheme:	Dual up-conversion, no frequency inversion
Frequency Resolution:	10 Hz
IF-Input Characteristics:	Frequency: 70 ± 20 MHz or 140 ± 40 MHz (optional: both → [IF-Band] = 70/140) Impedance: 50 or 75 Ω Return Loss: >20 dB IF-Connectors: BNC female
RF-Output Characteristics:	Impedance: 50 Ω Return Loss: >20 dB (>17 dB HCU3-CKuK) 1 dB Compression Point: >10 dBm Output Muting: >60 dB (by command or sense input or by alarm condition) RF-Signal Monitor: -20 dB of RF-output (approx.) RF-Connectors: SMA female (Standard) K female (RF output >18 GHz)
Transfer Characteristics:	Max. Conversion Gain: 40 dB Attenuation Range: 0...30 dB, Step 0.1 dB (Conversion Gain 40...10 dB) Gain Accuracy: ± 1 dB Level Stability: ± 0.25 dB/day (constant temperature) Amplitude Response: ±0.2 dB / ± 18 MHz, ± 0.25 dB / ±20 MHz, ±0.4 dB / ± 40 MHz Image Rejection: >80 dB Noise Figure: <25 dB, 20 dB typical
Equalizer (Gain Slope):	max ± 2.5 dB / 40 MHz (IF 70 MHz), max ± 4 dB / 80 MHz (IF 140 MHz) (programmable)
Group Delay (± 18 MHz):	Linear: 0.03 ns / MHz max. Parabolic: 0.01 ns / MHz ² max. Ripple: 1 ns peak to peak max.
Group Delay (± 36 MHz):	Linear: 0.015 ns / MHz max. Parabolic: 0.005 ns / MHz ² max. Ripple: 2 ns peak to peak max.
Intermodulation (3rd Order):	-36 dBc max (f _{in} : 67.5 and 72.5 MHz, P _{in} : 2 x -25 dBm, P _{out} : 2 x 0 dBm)
AM / PM conversion:	0.1° / dB (P _{out} = 0 dBm)
Spurious Outputs:	Signal related: < - 60 dBc (Δf < 1 MHz), < -70 dBc (Δf ≥ 1 MHz) Signal independent: < - 70 dBm
Frequency Stability:	± 1 x 10 ⁻⁷ , 0°C ... 50°C ± 2 x 10 ⁻⁸ , 0°C ... 50°C (after 30 min warm up) ± 1.5 x 10 ⁻⁹ per day (fixed temperature after 24 h warm up)
Reference Input:	Frequency: 10 MHz or 5 MHz Level: -3...10 dBm Modes: internal, external, auto (senses reference input) Connector: BNC female
Reference Output:	Frequency: 10 MHz Level: 0 ± 3 dBm Connector: BNC female
Monitoring and Control Interface:	Protocol: SNMP Connection: UDP over Ethernet (10 or 100 Mbps, auto sensing), connector RJ-45
	Protocol: HTTP (web browser interface) Connection: TCP/IP over Ethernet (10 or 100 Mbps, auto sensing), connector RJ-45
	Protocol: Multipoint Connection: RS232 or RS422/RS485 (configurable), connector DSUB09 female or TCP/IP over Ethernet (10 or 100 Mbps, auto sensing), connector RJ-45
Alarm Interface: Mute Input:	Alarm: two potential free contacts (DPDT), Mute Input: TTL logic input with internal pull up Connector DSUB09 female
Temperature Range:	HCU: -30°C ... 60°C operating (10 minutes warm up at -30°C) SCU: 0°C ... 50°C operating -30°C ... 80°C storage
Relative Humidity:	< 95 % non condensing
User Interface:	SCU: LCD-Display 2 x 40 characters, 4 cursor keys, 4 function keys HCU: VFD-Display 2 x 40 characters, 4 cursor keys, 4 function keys
Mains Power Input:	100 ... 240 V AC nominal, 90...264 V AC max, 50...60 Hz
Mains Power Consumption:	Max: 38 VA / 25 W (single converters) Typ: 35 VA / 23 W (single converters)
Mains Power Input	IEC C14
Mains Fuse:	2 x 3.15 A (or 2 A) time-lag fuse
Dimension and Weight:	483 x 44 x 505 mm ³ (WxHxD), 1 RU (19") approx. 8.4 kg

Specifications are subject to change

Satellite Upconverter

Indoor Version

Single / Dual / Triple Band Upconverter or Dual Channel Upconverter

S-Type (standard version), H-Type (extended temperature range)

Order Information:	HCU-[RF Band(s)]-[IF Band in MHz]-[IF Imp in Ω]-[Options] converter	Single or Dual
	HCUx-[RF Band(s)]-[IF Band in MHz]-[IF Imp in Ω]-[Options]	Multiband converter
	SCU-[RF Band(s)]-[IF Band in MHz]-[IF Imp in Ω]-[Options] converter	Single or Dual
	SCUx-[RF Band(s)]-[IF Band in MHz]-[IF Imp in Ω]-[Options] x=2: Dualband converter, x=3: Tripleband converter	Multiband converter
	Possible Options are: FAN (internal Fan) IFT (additional IF test output) VFD (VFD display, standard with HCU-type converters)	
	Examples:	
	HCU-C-70-50 (C-band upconverter)	
	SCU-Ku-140-75-FAN (Ku-band upconverter with internal Fan)	
	HCU-C-70/140-50 (C-Band upconverter dual IF 70 and 140 MHz)	
	HCU3-CXKu-70-50 (Tripleband upconverter)	
	SCU-CKu-70-75 (Dual channel upconverter C-band and Ku-band, identical IF and impedance)	
	SCU-C-70-75/Ku-140-50-FAN (Dual channel upconverter C-band and Ku-band with Fan, different IF and impedance)	

Satellite Downconverter

Indoor Version

Single / Dual / Triple Band Downconverter or Dual Channel Downconverter
S-Type (standard version), H-Type (extended temperature range)

Downconverter Type:	HCD-S / SCD-S	HCD-S4 / SCD-S4	HCD-C / SCD-C	HCD-C1 / SCD-C1
RF-Input Frequency:	S-Band 2.025...2.290 GHz**	S-Band 2.0...2.6 GHz	C-Band 3.4...4.2 GHz	C-Band 3.4...4.8 GHz
Intermediate Frequency:	2450 MHz for 70 MHz IF Output 2440 MHz for 140 MHz IF Output	3050 MHz for 70 MHz IF Input 3040 MHz for 140 MHz IF Input	2150 MHz for 70 MHz IF Output 2140 MHz for 140 MHz IF Output	2150 MHz for 70 MHz IF Output 2140 MHz for 140 MHz IF Output
Phase Noise:	10 Hz 100 Hz 1 kHz 10 kHz 100 kHz 1 MHz	-60 -80 -90 -98 -103 ¹⁾ -112 ¹⁾	-56 -76 -86 -96 -101 ¹⁾ -111 ¹⁾	-53 -73 -83 -93 -98 ¹⁾ -108 ¹⁾
	max. values in dBc/ Hz ¹⁾ 0°C ... 50°C, outside this temperature range degraded by max 5 dB.			
Test Output (Fixed Oscillator):	2520 MHz (70 MHz IF) 2580 MHz (140 MHz IF) -6 ± 3 dBm, Connector SMA female	3120 MHz (70 MHz IF) 3160 MHz (140 MHz IF) -6 ± 3 dBm SMA female	2220 MHz (70 MHz IF) 2280 MHz (140 MHz IF) -6 ± 3 dBm, Connector SMA female	2220 MHz (70 MHz IF) 2280 MHz (140 MHz IF) -6 ± 3 dBm, Connector SMA female
Test Output (Microwave Oscillator):	4.475...4.74 GHz (70 MHz IF) 4.465...4.73 GHz (140 MHz IF) -7 ± 3 dBm SMA female	5.05...5.65 GHz (70 MHz IF) 5.04...5.64 GHz (140 MHz IF) -7 ± 3 dBm SMA female	5.55...6.35 GHz (70 MHz IF) 5.54...6.34 GHz (140 MHz IF) -7 ± 3 dBm ²⁾ SMA female	5.55...6.95 GHz (70 MHz IF) 5.54...6.94 GHz (140 MHz IF) -7 ± 3 dBm ²⁾ SMA female

Downconverter Type:	HCD-X	HCD-Ku / SCD-Ku	HCD-Ku4 / SCD-Ku4	
RF-Input Frequency:	X-Band 7.25...7.75 GHz	Ku-Band 10.70...12.75 GHz	Ku-Band 9.3...9.5 GHz	
Intermediate Frequency:	2150 MHz for 70 MHz IF Output 2140 MHz for 140 MHz IF Output	2150 MHz for 70 MHz IF Output 2140 MHz for 140 MHz IF Output	2150 MHz for 70 MHz IF Output 2140 MHz for 140 MHz IF Output	
Phase Noise:	10 Hz 100 Hz 1 kHz 10 kHz 100 kHz 1 MHz	-53 -73 -83 -93 -98 ¹⁾ -108 ¹⁾	-50 -70 -80 -90 -95 ¹⁾ -105 ¹⁾	
	max. values in dBc/ Hz ¹⁾ 0°C ... 50°C, outside this temperature range degraded by max 5 dB.			
Test Output (Fixed Oscillator):	2220 MHz (70 MHz IF) 2280 MHz (140 MHz IF) -6 ± 3 dBm, Connector SMA female	2220 MHz (70 MHz IF) 2280 MHz (140 MHz IF) -6 ± 3 dBm, Connector SMA female	2220 MHz (70 MHz IF) 2280 MHz (140 MHz IF) -6 ± 3 dBm, Connector SMA female	
Test Output (Microwave Oscillator):	9.40...9.90 GHz (70 MHz IF) 9.39...9.89 GHz (140 MHz IF) -7 ± 3 dBm ²⁾ SMA female	12.85...14.90 GHz (70 MHz IF) 12.84...14.89 GHz (140 MHz IF) -7 ± 3 dBm ²⁾ SMA female	11.45...11.65 GHz (70 MHz IF) 11.44...11.64 GHz (140 MHz IF) -7 ± 3 dBm ²⁾ SMA female	

Specifications continued next page

²⁾ -12 ± 3 dBm for Dual-Band units and Triple-Band units e.g. HCD3-CXKu

Satellite Downconverter

Indoor Version

Single / Dual / Triple Band Downconverter or Dual Channel Downconverter S-Type (standard version), H-Type (extended temperature range)

Specifications continued:

Downconverter Type:	HCD-Ka3-2 / SCD-Ka3-2	HCD-Ka6 / SCD-Ka6	HCD-Ka7 / SCD-Ka7	
RF-Input Frequency:	Ka-Band 17.7...19.5 GHz 19.4...21.2 GHz (automatically switched)	Ka-Band 18.1...21.2 GHz	Ka-Band 25.5...27.5 GHz	
Intermediate Frequency:	2450 MHz for 70 MHz IF Output 2440 MHz for 140 MHz IF Output	2450 MHz for 70 MHz IF Input 2440 MHz for 140 MHz IF Input t	2450 MHz for 70 MHz IF Input 2440 MHz for 140 MHz IF Input t	
Phase Noise:	10 Hz 100 Hz 1 kHz 10 kHz 100 kHz 1 MHz	-50 -70 -80 -90 -95 ¹⁾ -105 ¹⁾	-46 -66 -76 -86 -88 ¹⁾ -101 ¹⁾	
	max. values in dBc/ Hz ¹⁾ 0°C ... 50°C, outside this temperature range degraded by max 5 dB.			
Test Output (Fixed Oscillator):	2380 MHz (70 MHz IF) 2300 MHz (140MHzIF) -6 ± 3 dBm SMA female	2380 MHz (70 MHz IF) 2300 MHz (140MHzIF) -6 ± 3 dBm SMA female	2380 MHz (70 MHz IF) 2300 MHz (140MHzIF) -6 ± 3 dBm SMA female	
Test Output (Microwave Oscillator):	15.25...18.75 GHz (70 MHz IF) 15.26...18.76 GHz (140 MHz IF) - 7 ± 3 dBm SMA female	15.65...18.75 GHz (70 MHz IF) 15.66...18.76 GHz (140 MHz IF) - 7 ± 3 dBm SMA female	11.525...12.525 GHz (70 MHz IF) 11.53...12.53 GHz (140 MHz IF) - 7 ± 3 dBm SMA female	

Specifications continued next page

Satellite Downconverter

Indoor Version

Single / Dual / Triple Band Downconverter or Dual Channel Downconverter S-Type (standard version), H-Type (extended temperature range)

Specifications continued:

Conversion Scheme:	Dual down-conversion, no frequency inversion
Frequency Resolution:	10 Hz
RF-Input Characteristics:	Impedance: 50 Ω Return Loss: >20 dB Max. input level: < approx. -25 dBm (operational) < approx. +10 dBm (damage level) LO Leakage: < -80 dBm RF-Connector: SMA female (Standard) K female (RF Input > 18 GHz)
IF-Output Characteristics:	Frequency: 70 \pm 20 MHz or 140 \pm 40 MHz (optional: both \rightarrow [IF-Band] = 70/140) Impedance: 50 or 75 Ω Return Loss: >20 dB 1 dB Compression Point: >10 dBm, 13 dBm typical Output Muting: >60 dB (by command or sense input or by alarm condition) IF-Signal Monitor: -20 dB of IF-output (approx.) IF-Connectors: BNC female
Transfer Characteristics:	Max. Conversion Gain: 45 dB (Standard) Attenuation Range: 0...30 dB, Step 0.1 dB (Conversion Gain 45...15 dB) Gain Accuracy: \pm 1 dB Level Stability: \pm 0.25 dB/day (constant temperature) Amplitude Response: \pm 0.2 dB / \pm 18 MHz, \pm 0.25 dB / \pm 20 MHz, \pm 0.4 dB / \pm 40 MHz Image Rejection: >80 dB Noise Figure: <12 dB, 10 dB typical
Equalizer (Gain Slope):	max \pm 2.5 dB / 40 MHz (IF 70 MHz), max \pm 4 dB / 80 MHz (IF 140 MHz) (programmable)
Group Delay (\pm 18 MHz):	Linear: 0.03 ns / MHz max. Parabolic: 0.01 ns / MHz ² max. Ripple: 1 ns peak to peak max.
Group Delay (\pm 36 MHz):	Linear: 0.015 ns / MHz max. Parabolic: 0.005 ns / MHz ² max. Ripple: 2 ns peak to peak max.
Intermodulation (3rd Order):	-60 dBc max (Δf_{in} : 5 MHz, P_{in} : 2 x -40 dBm, P_{out} : 2 x -10 dBm)
AM / PM conversion:	0.1° / dB (P_{out} = 0 dBm)
Spurious Outputs:	Signal related: < -60 dBc (Δf < 1 MHz), < -70 dBc ($\Delta f \geq$ 1 MHz) Signal independent: < -76 dBm (< -80 dBm typical)
Frequency Stability:	\pm 1 x 10 ⁻⁷ , 0°C ... 50°C \pm 2 x 10 ⁻⁸ , 0°C ... 50°C (after 30 min warm up) \pm 1.5 x 10 ⁻⁹ per day (fixed temperature after 24 h warm up)
Reference Input:	Frequency: 10 MHz or 5 MHz Level: -3...10 dBm Modes: internal, external, auto (senses reference input) Connector: BNC female
Reference Output	Frequency: 10 MHz Level: 0 \pm 3 dBm Connector: BNC female
Monitoring and Control Interface:	Protocol: SNMP Connection: UDP over Ethernet (10 or 100 Mbps, auto sensing), connector RJ-45 Protocol: HTTP (web browser interface) Connection: TCP/IP over Ethernet (10 or 100 Mbps, auto sensing), connector RJ-45 Protocol: Multipoint Connection: RS232 or RS422/RS485 (configurable), connector DSUB09 female or TCP/IP over Ethernet (10 or 100 Mbps, auto sensing), connector RJ-45
Alarm Interface: Mute Input:	Alarm: two potential free contacts (DPDT), Mute Input: TTL logic input with internal pull up Connector DSUB09 female
Temperature Range:	HCU : -30°C ... 60°C operating (10 minutes warm up at -30°C) SCU : 0°C ... 50°C operating -30°C ... 80°C storage
Relative Humidity:	< 95 % non condensing
User Interface:	SCU: LCD-Display 2 x 40 characters, 4 cursor keys, 4 function keys HCU: VFD-Display 2 x 40 characters, 4 cursor keys, 4 function keys
Mains Power Input:	100 ... 240 V AC nominal, 90...264 V AC max, 50...60 Hz
Mains Power Consumption:	Max: 38 VA / 25 W (single converters) Typ: 35 VA / 23 W (single converters)
Mains Power Input Connector:	IEC C14
Mains Fuse:	2 x 3.15 A (or 2 A) time-lag fuse
Dimension and Weight:	483 x 44 x 505 mm ³ (WxHxD), 1 RU (19") approx. 8.2 kg

Specifications are subject to change

Satellite Downconverter

Indoor Version

Single / Dual / Triple Band Downconverter or Dual Channel Downconverter

S-Type (standard version), H-Type (extended temperature range)

Order Information:	HCD-[RF Band(s)]-[IF Band in MHz]-[IF Imp in Ω]-[Options] converter	Single or Dual
	HCDx-[RF Band(s)]-[IF Band in MHz]-[IF Imp in Ω]-[Options] converter	Multiband converter
	SCD-[RF Band(s)]-[IF Band in MHz]-[IF Imp in Ω]-[Options] converter	Single or Dual
	SCDx-[RF Band(s)]-[IF Band in MHz]-[IF Imp in Ω]-[Options] x=2: Dualband converter, x=3: Triband converter	Multiband converter
Possible Options are:	FAN (internal Fan)	
	VFD (VFD display, standard with HCD-type converters)	
	ALC-BW (Automatic level control- Filter bandwidth, see product: Automatic Level Control)	
	2RFI (two switchable RF inputs)	
Examples:	HCD-C-70-50 (C-band downconverter)	
	SCD-Ku-140-75-FAN (Ku-band downconverter with internal Fan)	
	HCD-C-70/140-50 (C-Band downconverter dual IF 70 and 140 MHz)	
	HCD3-CXKu-70-50 (Triband downconverter)	
	SCD2-CKu-70-75 (Dualband downconverter)	
	SCD-CKu-70-75 (Dual channel downconverter C-band and Ku-band, identical IF and impedance)	
	SCD-C-70-75/Ku-70-50-FAN (Dual channel downconverter C-band and Ku-band with Fan, different IF and impedance)	

Satellite Up- and Downconverter, Outdoor Version

Single / Dual / Triple Band
S-, C-, X-, Ku-, K-, Ka-Band



WORK Microwave provides its proven up- and downconverters also in an outdoor housing. The units can be operated over a temperature range -30°C to 60°C (-22°F to 140°F). In the non-operating mode they survive temperatures of -50°C to 80°C (-58°F to 176°F) without any damage. Same as the 19" rack converter units, they meet the requirements for modern satellite transmission such as TV up-link and high-speed data network. Because of their rugged construction and low power consumption, they are most suitable for fixed satellite earth stations, satellite news gathering (SNG) vehicles, Fly-Aways and other mobile applications.

Technology of the 4th Generation

All WORK Microwave outdoor converters are equipped with the most modern technology of WORK Microwave's 4th generation satellite converters. This design allowed us to reduce the number of components by more than 30%. In addition significant circuit improvements were made. This design results in an AC power consumption of typically 35 VA / 23 W. The housing includes special internal heat dissipation structures, resulting in a completely passively cooled unit. All this leads to high reliability and long lifetime.

Outdoor installation

WORK Microwave's outdoor converters are best fit to be mounted directly to the antenna. They do not require additional protection against water. The housing provides environmental protection according to IP67 (temporary flooding) when all cables are connected and sealed appropriately. Special environmental protection sleeves for the coaxial connectors allow optimal sealing from the housing to the cable, if these sleeves are used to seal the connection of the cable with adhesive shrinking tube or a rubber splicing tape (e.g. of type 3M/ScotchTM 130C). Additionally the housing should be mounted with the connector side down. Alternatively the connector panel can be in a vertical position.

S-, C-, X-, Ku-, K- and Ka-, single, dual or triple band coverage

WORK Microwave is offering the satellite outdoor converters as single band units covering S-, C-, X-, Ku-, K-Band and Ka-Band or as Dual or Triple band units covering a combination of these frequency bands. They support the standard IF-frequency of 70 ± 20 MHz or/and 140 ± 40 MHz. The conversion is performed without spectral inversion. All WORK Microwave upconverters offer an increased power output ($P_{1dB} = +10$ dBm) in all versions.

High signal integrity

The extreme low phase noise of the oscillators guarantees a very good signal quality. Low spurious emissions allow using the converters also in environments with demanding requirements, like high power video uplinks. Sophisticated temperature compensation guarantees gain stability over the full temperature range.

Operating and control – easy integration into your system

The converters can be operated via remote control (RS 232, RS422/485). Detailed monitoring of the system status and a summary alarm output (dual change over switch contacts) are provided. For the remote control either ASCII string based commands as well as addressable, packet based commands are provided.

A separate 19" rack mount remote control unit allows remote control of one or more units. The front panel of this unit is similar to the front panel of the 19" rack mount type.

Customized products

In addition to standard products WORK Microwave offers custom tailored products and specialized products as follows:

- Modified or smaller housings
- Different IF or RF frequency
- Customized M&C interface and control syntax
- Extended storage or operating temperature range
- Military versions for hostile environment (shock, vibration, humidity)

Key features

- 70 MHz or 140 MHz IF bands available
- Optional switchable IF 70 MHz and 140 MHz (IF 70/140)
- Extreme low power consumption typical 32 VA / 20 W (single band unit) 35VA / 23W (triple band units)
- Extreme low phase noise (< -50 dBc/Hz @10 Hz)

- Long term stability 10^{-7} / year
- Output power +10 dBm (1 dB compression point)
- Low spurious emissions < -80 dBm at full gain (high performance series)
- Adjustable equalizer
- Digital gain compensation
- Operating temperature range -30°C to 60°C (-22°F to 140°F), storage temperature -50°C to 80°C (-58°F to 140°F)
- Remote control through RS232 and RS422/485 (2-wire or 4-wire bus) interfaces
- Packet command syntax supports RS485 bus systems and allows addressed operation
- Summary alarm output (dual change over switch contacts) and transmit mute input
- IP 67 protected housing
- CE compliant
- **3 years warranty**

Order information

For the Outdoor version only the High Performance type is available due to environmental conditions which require the extended temperature range.

Open questions, demo units

If you need more information about WORK Microwave's 4th satellite converter generation or if you would like to have a demo unit, please contact us via e-mail: sales@work-microwave.de or call us. We are glad to assist you.

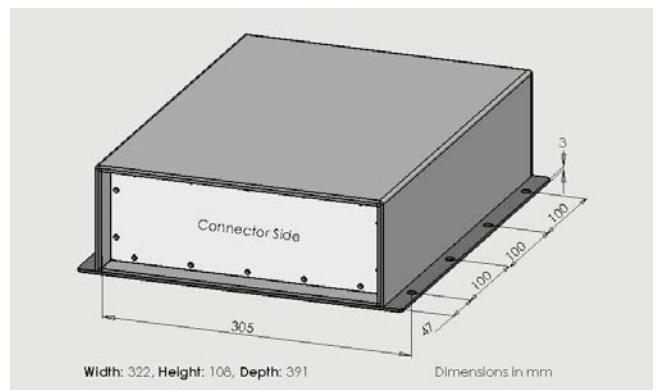

Dimensions of Outdoor Housing

Satellite Upconverter

Outdoor Version

Single / Dual / Triple Band
 S-, C-, X-, Ku-, K-, Ka-Band
 H-Type (extended temperature range)

Upconverter Type:	HCU-S-OD	HCU-C-OD	HCU-C1-OD	HCU-X-OD
RF-Output Frequency:	S-Band 2.025...2.110 GHz	C-Band 5.85...6.65 GHz	C-Band 5.85...7.025 GHz	X-Band 7.90...8.40 GHz
Intermediate Frequency:	2450 MHz for 70 MHz IF Input 2440 MHz for 140 MHz IF Input	2450 MHz for 70 MHz IF Input 2440 MHz for 140 MHz IF Input	2610 MHz for 70 MHz IF Input 2600 MHz for 140 MHz IF Input	2450 MHz for 70 MHz IF Input 2440 MHz for 140 MHz IF Input
Phase Noise:	10 Hz 100 Hz 1 kHz 10 kHz 100 kHz 1 MHz	-60 -80 -90 -100 -105 ¹⁾ -112 ¹⁾	-55 -75 -85 -95 -100 ¹⁾ -110 ¹⁾	-53 -73 -83 -93 -98 ¹⁾ -108 ¹⁾
max. values in dBc/ Hz ¹⁾ 0°C ... 50°C, outside this temperature range degraded by max 5 dB.				

Upconverter Type:	HCU-Ku-OD	HCU-K-OD	HCU-Ka-OD	Other bands
RF-Output Frequency:	Ku-Band 12.75...14.50 GHz	K-Band 17.3...18.4 GHz	Ka-Band 29.7...31.5 GHz	available on request as for HCU / SCU Indoor units
Intermediate Frequency:	2450 MHz for 70 MHz IF Input 2440 MHz for 140 MHz IF Input	2450 MHz for 70 MHz IF Input 2440 MHz for 140 MHz IF Input	2450 MHz for 70 MHz IF Input 2440 MHz for 140 MHz IF Input	
Phase Noise:	10 Hz 100 Hz 1 kHz 10 kHz 100 kHz 1 MHz	-50 -70 -80 -90 -95 ¹⁾ -105 ¹⁾	-50 -70 -80 -90 -95 ¹⁾ -105 ¹⁾	-46 -66 -76 -86 -88 ¹⁾ -101 ¹⁾
max. values in dBc/ Hz ¹⁾ 0°C ... 50°C, outside this temperature range degraded by max 5 dB.				

Conversion Scheme:	Dual up-conversion, no frequency inversion	
Frequency Resolution:	10 Hz	
IF-Input Characteristics:	Frequency:	70 ± 20 MHz or 140 ± 40 MHz (optional: both: [IF-Band] = 70/140, not in combination with Dualband or Triband units)
	Impedance:	50 or 75 Ω
	Return Loss:	>20 dB
	IF-Connectors:	N female
RF-Output Characteristics:	Impedance:	50 Ω
	Return Loss:	>20 dB **
	1 dB Compression Point:	>10 dBm
	Output Muting:	>60 dB (by command or sense input or by alarm condition)
	RF-Connectors:	SMA female K female (RF output >18 GHz)
Transfer Characteristics:	Max. Conversion Gain:	40 dB
	Attenuation Range:	0...30 dB, Step 0.1 dB (Conversion Gain 40...10 dB)
	Gain Accuracy:	± 1 dB
	Level Stability:	± 0.25 dB/day (constant temperature)
	Amplitude Response:	±0.2 dB / ± 18 MHz, ± 0.25 dB / ±20 MHz, ±0.4 dB / ± 40 MHz
	Image Rejection:	>80 dB
	Noise Figure:	<25 dB, 20 dB typical
Equalizer (Gain Slope):	max ± 2.5 dB / 40 MHz (IF 70 MHz), max ± 4 dB / 80 MHz (IF 140 MHz) (programmable)	
Group Delay (± 18 MHz):	Linear:	0.03 ns / MHz max.
	Parabolic:	0.01 ns / MHz ² max.
	Ripple:	1 ns peak to peak max.
Group Delay (± 36 MHz):	Linear:	0.015 ns / MHz max.
	Parabolic:	0.005 ns / MHz ² max.
	Ripple:	2 ns peak to peak max.
Intermodulation (3rd Order):	-36 dBc max (f _{in} : 67.5 and 72.5 MHz, P _{in} : 2 x -25 dBm, P _{out} : 2 x 0 dBm)	
AM / PM conversion:	0.1° / dB (P _{out} = 0 dBm)	
Spurious Outputs:	Signal related:	< -60 dBc (Δf < 1 MHz), < -70 dBc (Δf ≥ 1 MHz)
	Signal independent:	< -70 dBm
Frequency Stability:	± 1 x 10 ⁻⁷ , 0°C ... 50°C ± 2 x 10 ⁻⁸ , 0°C ... 50°C (after 30 min warm up) ± 1.5 x 10 ⁻⁹ per day (fixed temperature after 24 h warm up)	

Specifications continued next page

Satellite Upconverter

Outdoor Version

Single / Dual / Triple Band
 S-, C-, X-, Ku-, K-Band
 H-Type (extended temperature range)

Specifications continued:

Reference Input (Option RIN):	Frequency: 10 MHz or 5 MHz Level: -3...10 dBm Modes: internal, external, auto (senses reference input) Impedance: 50 Ω Connector: SMA female
Reference Output (Option ROUT):	Frequency: 10 MHz Level: 0 ± 3 dBm Impedance: 50 Ω Connector: SMA female
Monitoring and Control Interface:	RS232 or RS422/RS485 Alarm Output: Two potential free contacts (DPDT) 24 V DC output: max 0,3 A 6,5 V DC output: max 0,2 A Mute Input: TTL logic input with internal pull up (Connector type: MIL-C-26482: MS 3120 E 14-19 S)
Temperature Range:	HCU : -30°C ... 60°C operating (10 minutes warm up at -30°C) -30°C ... 80°C storage
Relative Humidity:	<100 %
Mains Power Input:	100 ... 240 V AC nominal, 90...264 V AC max, 50...60 Hz
Mains Power Consumption:	Max: 35 VA / 22 W (single converters) Typ: 32 VA / 20 W (single converters)
Mains Power Input Connector:	Amphenol C16-1 (3+PE) male
Dimension and Weight:	322 x 108 x 391 mm ³ (WxHxD) approx. 8.4 kg
Degree of Protection:	IP 67 (acc. IEC 529)

Specifications are subject to change

Order Information:

HCU-[RF Band(s)]-[IF Band in MHz]-[IF Imp in Ω]-[Options] Single or Dual upconverter
HCUx-[RF Band(s)]-[IF Band in MHz]-[IF Imp in Ω]-[Options] Multiband upconverter
 x=2: Dualband converter, x=3: Triband converter

Possible Options are: RIN (reference input)
 ROUT (reference output)

Examples:

HCU-X-OD-70-50 (X-band upconverter)
HCU3-CXKu-70-50 (triband upconverter)
HCU-Ku-OD-70-50-RIN (Ku band upconverter with reference input)
HCU-Ku-OD-70/140-50 (Ku band upconverter with 70/140 MHz IF switchable)

Satellite Downconverter

Outdoor Version

Single / Dual / Triple Band
S-, C-, X-, Ku-Band
H-Type (extended temperature range)

Downconverter Type:	HCD-S-OD	HCD-C-OD	HCD-C1-OD	Other bands
RF-Input Frequency:	S-Band 2.2...2.3 GHz	C-Band 3.4...4.2 GHz	C-Band 3.4...4.8 GHz	available on request as for HCD / SCD Indoor units
Intermediate Frequency:	2450 MHz for 70 MHz IF Output 2440 MHz for 140 MHz IF Output	2150 MHz for 70 MHz IF Output 2140 MHz for 140 MHz IF Output	2150 MHz for 70 MHz IF Output 2140 MHz for 140 MHz IF Output	
Phase Noise:	10 Hz 100 Hz 1 kHz 10 kHz 100 kHz 1 MHz	-60 -80 -90 -96 -105 ¹⁾ -112 ¹⁾	-56 -76 -86 -96 -101 ¹⁾ -111 ¹⁾	-56 -76 -86 -96 -101 ¹⁾ -111 ¹⁾
max. values in dBc/ Hz ¹⁾ 0°C ... 50°C, outside this temperature range degraded by max 5 dB.				

Downconverter Type:	HCD-X-OD	HCD-Ku-OD	HCD-Ku4-OD	HCD-Ka4-OD
RF-Input Frequency:	X-Band 7.25...7.75 GHz	Ku-Band 10.70...12.75 GHz	Ku-Band 9.3...9.5 GHz	Ka-Band 27.5...31 GHz
Intermediate Frequency:	2150 MHz for 70 MHz IF Output 2140 MHz for 140 MHz IF Output	2150 MHz for 70 MHz IF Output 2140 MHz for 140 MHz IF Output	2150 MHz for 70 MHz IF Output 2140 MHz for 140 MHz IF Output	5170 MHz for 70 MHz IF Input 5100 MHz for 140 MHz IF Input
Phase Noise:	10 Hz 100 Hz 1 kHz 10 kHz 100 kHz 1 MHz	-53 -73 -83 -93 -8 ¹⁾ -108 ¹⁾	-50 -70 -80 -90 -95 ¹⁾ -105 ¹⁾	-46 -66 -76 -86 -88 ¹⁾ -101 ¹⁾
max. values in dBc/ Hz ¹⁾ 0°C ... 50°C, outside this temperature range degraded by max 5 dB.				

Conversion Scheme:	Dual down-conversion, no frequency inversion	
Frequency Resolution:	10 Hz	
RF-Input Characteristics:	Impedance:	50 Ω
	Return Loss:	>20 dB
	Max. input level:	< approx. -25 dBm (operational) < approx. +10 dBm (damage level)
	LO Leakage:	<-80 dBm
	RF-Connector:	SMA female K female (RF input >18 GHz)
IF-Output Characteristics:	Frequency:	70 ± 20 MHz or 140 ± 40 MHz (optional: both: [IF-Band] = 70/140, not in combination with Dualband or Triband units)
	Impedance:	50 or 75 Ω
	Return Loss:	<20 dB
	1 dB Compression Point:	>10 dBm, 13 dBm typical
	Output Muting:	>60 dB (by command or sense input or by alarm condition)
	IF-Connectors:	N female
Transfer Characteristics:	Max. Conversion Gain:	45 dB
	Attenuation Range:	0...30 dB, Step 0.1 dB (Conversion Gain 45...15 dB)
	Gain Accuracy:	± 1 dB
	Level Stability:	± 0.25 dB/day (constant temperature)
	Amplitude Response:	±0.2 dB / ± 18 MHz, ± 0.25 dB / ±20 MHz, ±0.4 dB / ± 40 MHz
	Image Rejection:	>80 dB
	Noise Figure:	<12 dB, 10 dB typical
Equalizer (Gain Slope):	max ± 2.5 dB / 40 MHz (IF 70 MHz), max ± 4 dB / 80 MHz (IF 140 MHz) (programmable)	
Group Delay (± 18 MHz):	Linear:	0.03 ns / MHz max.
	Parabolic:	0.01 ns / MHz ² max.
	Ripple:	1 ns peak to peak max.
Group Delay (± 36 MHz):	Linear:	0.015 ns / MHz max.
	Parabolic:	0.005 ns / MHz ² max.
	Ripple:	2 ns peak to peak max.
Intermodulation (3rd Order):	-60 dBc max (Δf _{in} : 5 MHz, P _{in} : 2 x -40 dBm, P _{out} : 2 x -10 dBm)	
AM / PM conversion:	0.1° / dB (P _{out} = 0 dBm)	
Spurious Outputs:	Signal related:	< - 60 dBc (Δf < 1 MHz), < -70 dBc (Δf ≥ 1 MHz)
	Signal independent:	< - 76 dBm (< - 80 dBm typical)

Specifications continued next page

Satellite Downconverter

Outdoor Version

Single / Dual / Triple Band
S-, C-, X-, Ku-, K-Band

Specifications continued:

Frequency Stability:	$\pm 1 \times 10^{-7}$, 0°C ... 50°C $\pm 2 \times 10^{-8}$, 0°C ... 50°C (after 30 min warm up) $\pm 1.5 \times 10^{-9}$ per day (fixed temperature after 24 h warm up)
Reference Input (Option RIN):	Frequency: 10 MHz or 5 MHz Level: -3...10 dBm Modes: internal, external, auto (senses reference input) Impedance: 50 Ω Connector: SMA female
Reference Output (Option ROUT):	Frequency: 10 MHz Level: 0 ± 3 dBm Impedance: 50 Ω Connector: SMA female
Monitoring and Control Interface:	RS232 or RS422/RS485 Alarm Output: Two potential free contacts (DPDT) 24 V DC output: max 0,3 A 6,5 V DC output: max 0,2 A Mute Input: TTL logic input with internal pull up (Connector type: MIL-C-26482: MS 3120 E 14-19 S)
Temperature Range:	HCU : -30°C ... 60°C operating (10 minutes warm up at -30°C) -30°C ... 80°C storage
Relative Humidity:	<100 %
Mains Power Input:	100 ... 240 V AC nominal, 90...264 V AC max, 50...60 Hz
Mains Power Consumption:	Max: 35 VA / 22 W (single converters) Typ: 32 VA / 20 W (single converters)
Mains Power Input Connector:	Amphenol C16-1 (3+PE) male
Dimension and Weight:	322 x 108 x 391 mm ³ (WxHxD) approx. 8.4 kg
Degree of Protection:	IP 67 (acc. IEC 529)

Specifications are subject to change

Order Information:

HCD-[RF Band]-[IF Band in MHz]-[IF Imp in Ω]-[Options] Single converter
HCDx-[RF Band(s)]-[IF Band in MHz]-[IF Imp in Ω]-[Options] Multiband converter
 x=2: Dualband converter, x=3: Triband converter

Possible Options are: **RIN** (reference input)
ROUT(reference output)

Examples:

HCD-X-OD-70-50 (X-band downconverter)
HCD3-CXKu-70-50 (triband downconverter)
HCD-Ku-OD-70-50-RIN (Ku band downconverter with reference input)
HCD-Ku-OD-70/140-50 (Ku band downconverter with 70/140 MHz IF switchable)

Dual Channel, Shared Oscillator Downconverter

S-, Ku-, Ka-Band

Triple Channel Converters also available

Also available as Outdoor Version



The satellite downconverters developed and manufactured by WORK Microwave are designed to meet the requirements of modern satellite transmission. Customers worldwide appreciate their reliability and high level of quality. These types of dual channel, shared oscillator converters can be used in systems, where an accurate phase relationship is required between two converter channels, as it is e.g. the case for monopulse tracking system down conversion.

Operating and control

The converters can be operated via the push buttons on the front panel using self-explanatory display menus or via remote control (RS232, RS422/485, TCP/IP over Ethernet).

Detailed monitoring of the system status and a summary alarm output (dual change over switch contacts) are provided. For the remote control either ASCII string based commands as well as addressable, packet based commands are provided.

Housing options

The converters normally are delivered without fans and can be operated in environments, where at minimum 1 RU space for natural ventilation is available above each unit. This eliminates the fan as potential point of failure. For rack installations without any space in between the units a fan within the converter unit is recommended, which forces an airflow from the right side to left side of the units. Outdoor versions with IP67 degree of protection are also available.

Key features

- Shared oscillator to guarantee excellent phase tracking in between channels
- 70 MHz or 140 MHz IF bands available
- Low power consumption
- Extreme low phase noise (< -60 dBc/Hz @ 10 Hz)
- Long- term stability 10^{-7} / year
- Output power +10 dBm (1 dB compression point)
- Automatic reference recognition (5 and 10 MHz)
- 0°C to 50°C (32°F to 122°F) (SCD units)
-30°C to 60°C (-22°F to 140°F) (HCD units)
- Remote control through RS232, RS422/485 (2-wire or 4-wire) interfaces. Packet command syntax supports RS485 bus systems and allows addressed operation.
- Remote control through Ethernet supporting a TCP/IP command interface (Indoor Version only)
- IF test outputs (standard on indoor units, on outdoor units with Option IFT)
- Summary alarm output (dual change over switch contacts)
- Internal Fan (Option FAN, Indoor Version only)
- CE compliant
- **3 years warranty**

Dual Channel, Shared Oscillator Downconverter

Downconverter Type:	HCD-SST / SCD-SST	HCD-KuKuT / SCD-KuKuT	HCD-KaKaT / SCD-KaKaT	
RF-Input Frequency:	S-Band 2.2...2.3 GHz	Ku-Band 10.70...12.75 GHz	Ku-Band 19.70...20.10 GHz	other frequency bands on request
Intermediate Frequency:	2450 MHz for 70 MHz IF Output 2440 MHz for 140 MHz IF Output	2150 MHz for 70 MHz IF Output 2140 MHz for 140 MHz IF Output	2150 MHz for 70 MHz IF Output 2140 MHz for 140 MHz IF Output	
Phase Noise:	10 Hz 100 Hz 1 kHz 10 kHz 100 kHz 1 MHz	-60 -80 -90 -98 -103 ¹⁾ -112 ¹⁾	-50 -70 -80 -90 -95 ¹⁾ -105 ¹⁾	-50 -70 -80 -90 -95 ¹⁾ -105 ¹⁾
	max. values in dBc/ Hz ¹⁾ 0°C ... 50°C, outside this temperature range degraded by max 5 dB.			
Test Output (Fixed Oscillator):	2520 MHz (70 MHz IF) 2580 MHz (140 MHz IF) -6 ± 3 dBm, Connector SMA female	2220 MHz (70 MHz IF) 2280 MHz (140 MHz IF) -6 ± 3 dBm, Connector SMA female	2220 MHz (70 MHz IF) 2280 MHz (140 MHz IF) -6 ± 3 dBm, Connector SMA female	
Test Output (Microwave Oscillator):	4.65...4.75 GHz (70 MHz IF) 4.64...4.74 GHz (140 MHz IF) -7 ± 3 dBm SMA female	12.85...14.90 GHz (70 MHz IF) 12.84...14.89 GHz (140 MHz IF) -7 ± 3 dBm SMA female	8.775...8.975 GHz (70 MHz IF) 8.78...8.98 GHz (140 MHz IF) -7 ± 3 dBm SMA female	
Conversion Scheme:	Dual down-conversion, no frequency inversion Two channels with shared oscillators: Same conversion frequency for both channels Gain setting individual for each channel			
Phase Tracking between channels:	<10 deg rms after 1 hour warmup constant gain setting, constant frequency setting, signal frequency constant within 10 kHz. Initial phase difference to be compensated externally.			
Frequency Resolution:	10 Hz			
RF-Input Characteristics:	Impedance: Return Loss: Max. input level: LO Leakage: RF-Connector:	50 Ω >20 dB < approx. -25 dBm (operational) < approx. +10 dBm (damage level) <-80 dBm SMA female		
IF-Output Characteristics:	Frequency: Impedance: Return Loss: 1 dB Compression Point: Output Muting: IF-Signal Monitor: IF-Connectors:	70 ± 20 MHz or 140 ± 40 MHz 50 or 75 Ω >20 dB >10 dBm, 13 dBm typical >60 dB (by command or sense input or by alarm condition) -20 dB of IF-output on front panel, SMA female (Standard on Indoor unit) -20 dB of IF output, SMA female (Outdoor unit with Option IFT) BNC female (Indoor Version) N female (Outdoor Version)		
Transfer Characteristics:	Max. Conversion Gain: Attenuation Range: Gain Accuracy: Level Stability: Amplitude Response: Image Rejection: Noise Figure: Isolation between channels:	45 dB 0...30 dB, Step 0.1 dB (Conversion Gain 45...15 dB) ± 2 dB ± 0.25 dB/day (constant temperature) ±0.2 dB / ± 18 MHz, ± 0.25 dB / ±20 MHz, ±0.4 dB / ± 40 MHz >80 dB <12 dB, 10 dB typical > 60 dB		
Group Delay (± 18 MHz):	Linear: Parabolic: Ripple:	0.03 ns / MHz max. 0.01 ns / MHz ² max. 1 ns peak to peak max.		
Group Delay (± 36 MHz):	Linear: Parabolic: Ripple:	0.015 ns / MHz max. 0.005 ns / MHz ² max. 2 ns peak to peak max.		
Intermodulation (3rd Order):	-60 dBc max (Δf _{in} : 5 MHz, P _{in} : 2 x -40 dBm, P _{out} : 2 x -10 dBm)			
AM / PM conversion:	0.1° / dB (P _{out} = 0 dBm)			
Spurious Outputs:	Signal related: Signal independent:	< -60 dBc (Δf < 1 MHz), < -70 dBc (Δf ≥ 1 MHz) < -76 dBm (< -80 dBm typical)		
Frequency Stability:	± 1 x 10 ⁻⁷ , 0°C ... 50°C ± 2 x 10 ⁻⁸ , 0°C ... 50°C (after 30 min warm up) ± 1.5 x 10 ⁻⁸ per day (fixed temperature after 24 h warm up)			
Reference Input:	Frequency: Level: Modes: Connector:	10 MHz or 5 MHz -3...10 dBm internal, external, auto (senses reference input) BNC female (Indoor Version) SMA female (Outdoor Version)		Standard on Indoor Version With Option RIN on Outdoor Version
Reference Output	Frequency: Level: Connector:	10 MHz 0 ± 3 dBm BNC female (Indoor Version)		on Indoor Version only

Specifications continued next page

Dual Channel, Shared Oscillator Downconverter

Specifications continued:

Monitoring and Control Interface:	TCP/IP over Ethernet (10 or 100 Mbps, auto sensing) RS232 or RS422/RS485 (Connectors DSUB09 female) (configurable by software) Alarm output: Two potential free contacts (DPDT, Connector DSUB09 female)	Indoor Version
	RS232 or RS422/RS485 Alarm output: Two potential free contacts (DPDT) 24 V DC output: max 0,3 A 6,5 V DC output: max 0,2 A Mute Input: TTL logic input with internal pull up (Connector type: MIL-C-26482: MS 3120 E 14-19 S)	Outdoor Version
MTBF	50000 hours (typical)	
Internal Fan	with Option FAN	Indoor Version only
Temperature Range:	HCU : -30°C ... 60°C operating (10 minutes warm up at -30°C) SCU: 0°C ... 50°C operating -30°C ... 80°C storage	Indoor Version
	-30°C ... 60°C operating (10 minutes warm up at -30 °C)	Outdoor Version
Relative Humidity:	<95 % non condensing	Indoor Version
	<100 %	Outdoor Version
User Interface:	SCU: LCD-Display 2 x 40 characters, 4 cursor keys, 2 function keys HCU: VFD-Display 2 x 40 characters, 4 cursor keys, 2 function keys	Indoor Version only
Mains Power Input:	100 ... 240 V AC nominal, 90...264 V AC max, 50...60 Hz	
Mains Power Consumption:	Max: 38 VA / 25 W Typ: 33 VA / 21 W	
Mains Power Input Connector:	IEC C14	Indoor Version
	Amphenol C16-1 (3+PE) male	Outdoor Version
Mains Fuse:	2 x 3.15 A (or 2 A) time-lag fuse	Indoor Version only
Dimension and Weight:	483 x 44 x 505 mm ³ (WxHxD), 1 RU (19") approx. 9 kg	Indoor Version
	402 x 111 x 391 mm ³ (WxHxD)	Outdoor Version
Degree of Protection:	IP 67 (acc. IEC 529)	Outdoor Version only

Specifications are subject to change

Order Information:

SCD-SST-[IF Band in MHz]-[IF Imp in Ω]-[Options]

Possible Options are: **VFD** (VFD display on Indoor SCD Version)
OD (Outdoor Unit)
RIN (Reference input on Outdoor Version)
IFT (IF test output on Outdoor Version)

Examples:

SCD-SST-70-50
SCD-SST-140-75-VFD
SCD-KuKuT-70-50-VFD

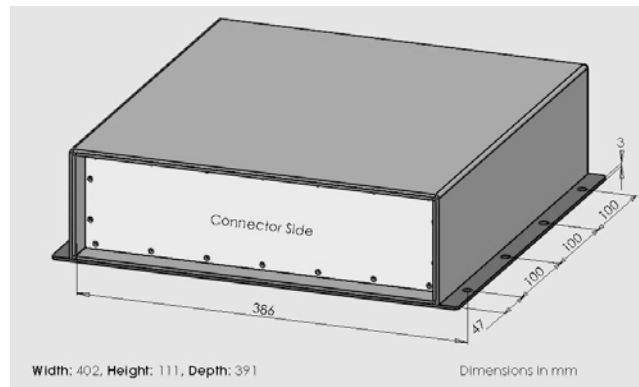

Dimensions of Outdoor Housing

Inmarsat Downconverter Narrowband Downconverter

L-Band to 70/140 MHz

S-Band to 725 MHz

140 MHz to 15 MHz

Single Conversion

Dual Channel Converters are also available.



These narrowband converters of WORK Microwave are designed to meet the requirements of specific applications, where often single conversion is sufficient as the required bandwidth coverage is quite narrow and the difference of the input and output frequency is not too big. They are based on the same proven core modules as used in the standard satellite upconverters and downconverters of WORK Microwave. Additional special functions can be included:

- Application specific filtering.
- Automatic level control. The output level is kept constant independent of the strength of the input signal with adjustable control characteristics.
- Additional PLO output.
- DC bias tee included at signal input to provide DC power to LNAs or LNBs.

Also a combination of two converters, resulting in a dual channel unit, is possible. One of these units can also be a dual conversion down-converter.

High signal integrity

The extreme low phase noise of the oscillators guarantees a very good signal quality. Low spurious emissions allow to use the converters also in environments with demanding requirements, like high power video uplinks. Sophisticated temperature compensation guarantees gain stability over a very wide temperature range.

Operating and control

The converters can be operated via the push buttons on the front panel using self-explanatory display menus or via remote control (RS232, RS422/485, TCP/IP over Ethernet).

Detailed monitoring of the system status and a summary alarm output (dual change over switch contacts) are provided. For the remote control either ASCII string based commands as well as addressable, packet based commands are provided.

Housing options

The converters normally are delivered without fans and can be operated in environments, where at minimum 1 RU (19") space for natural ventilation is available above each unit. This eliminates the fan as potential point of failure. For rack installations without any space in between the units a fan within the converter unit is recommended, which forces an airflow from the right side to left side of the units.

Inmarsat Downconverter

Indoor Version

L-Band to 70/140 MHz, Single or Dual Channel Downconverter S-Type (standard version), H-Type (extended temperature range)

Downconverter Type:	HCD-Lx / SCD-Lx or HCD-LxLx / SCD-LxLx	
RF-Input Frequency:	L-Band L1: 1525,0...1559,0 MHz (single band) L2: 1626,5...1660,5 MHz (single band) L: 1525,0...1559,0 MHz or 1626,5...1660,5 MHz (single band, input band front panel selectable) L1L1: 1525,0...1559,0 MHz and 1525,0...1559,0 MHz (dual channel) L2L2: 1626,5...1660,5 MHz and 1626,5...1660,5 MHz (dual channel) LL: 1525,0...1559,0 MHz or 1626,5...1660,5 MHz (dual channel, input band front panel selectable)	
Conversion Scheme:	Single down conversion, no frequency inversion	
LO-Frequency:	L1: 1402,0 MHz, L2: 1503,5 MHz	
RF-Input Characteristics:	Impedance:	50 Ω
	Return Loss:	>18 dB
	RF-Connector:	SMA female
	Max. Input Level:	-20 dBm @ IP3 < -60 dBc (operation) -10 dBm @ IP3 < -30 dBc (operation) +10 dBm (damage level)
	IIP ₃ :	0 dBm
	Cross Talk:	Unit 1 to IF out @ unit 2: < -80 dB (only dual channel)
IF-Output Characteristics:	Frequency:	140 ± 17 MHz
	Impedance:	50 or 75 Ω
	Return Loss:	>18 dB
	1 dB Compression Point:	>10 dBm, 13 dBm typical
	Output Muting:	>60 dB (by command or sense input or by alarm condition)
	IF-Signal Monitor:	-20dB of IF-output (approx.)
	IF-Connector:	SMA female
Transfer Characteristics:	Max. Conversion Gain:	35 dB
	Attenuation Range:	0...30 dB, Step 0.1 dB (Conversion Gain 35...5 dB)
	Gain Accuracy:	± 1 dB
	Level Stability:	± 0.25 dB/day (constant temperature)
	Amplitude Response:	± 0.5 dB / 10 MHz
	Noise Figure:	<16 dB
Equalizer (Gain Slope):	± 2.5 dB / 40 MHz (programmable)	
Intermodulation (3rd Order):	-60 dBc max (Δf_m : 5 MHz, P_{in} : 2 x -40 dBm, P_{out} : 2 x -10 dBm)	
Phase Noise :	10 Hz	-55 dBc/Hz
	100 Hz	-75 dBc/Hz
	1 kHz	-85 dBc/Hz
	10 kHz	-95 dBc/Hz
	100 kHz	-100 dBc/Hz ¹⁾
	1 MHz	-120 dBc/Hz ¹⁾
	¹⁾ 0°C ... 50°C, outside this temperature range degraded by max 5 dB.	
Spurious Outputs:	Signal related:	< -60 dBc (Δf < 1 MHz), < -70 dBc (Δf ≥ 1 MHz)
	Signal independent:	< -76 dBm (< -80 dBm typical)
Frequency Stability:	± 1 x 10 ⁻⁷ , 0°C ... 50°C ± 2 x 10 ⁻⁸ , 0°C ... 50°C (after 30 min warm up) ± 1.5 x 10 ⁻⁹ per day (fixed temperature after 24 h warm up)	
Reference Input:	Frequency:	10 MHz or 5 MHz
	Level:	-5...10 dBm
	Modes:	internal, external, auto (senses reference input)
	Connector:	SMA female
Reference Output:	Frequency:	10 MHz
	Impedance:	50 Ω
	Return Loss:	>15 dB
	Level:	0 ± 3 dBm
	Connector:	SMA female
Reference Output (Option PLO187):	Frequency:	187.20 MHz (other frequencies on request)
	Impedance:	50 Ω
	Return Loss:	>15 dB
	Harmonics:	<-40 dBc
	Level:	11 ± 1.5 dBm
	Connector:	SMA female
DC Power to external LNA (Option DC15):	DC bias tee included at signal input	
	DC Voltage :	15 V (other voltages on request)
	DC Current :	<0.4 A (each output)
	Switchable:	ON / OFF
	Protection:	Short circuit protection
Monitoring and Control Interface:	RS232 or RS422/RS485 (Connectors DSUB09 female) (selectable by customer), TCP/IP over Ethernet, 10/100 Base-T (RJ45 connector)	
Alarm Interface: Mute Input:	Two potential free contacts (DPDT) Mute Input: TTL logic input with internal pull up Connector DSUB09 female)	
Temperature Range:	HCU : -30°C ... 60°C operating (10 minutes warm up at -30°C) SCU : 0°C ... 50°C operating -30°C ... 80°C storage	
Relative Humidity:	< 95 % non condensing	

Inmarsat Downconverter

Indoor Version

L-Band to 70/140 MHz Downconverter

S-Type (standard version), H-Type (extended temperature range)

Specifications continued:

User Interface:	SCU: LCD-Display 2 x 40 characters, 4 cursor keys, 4 function keys HCU: VFD-Display 2 x 40 characters, 4 cursor keys, 4 function keys
Mains Power Input:	100 ... 240 V AC nominal, 90...264 V AC max, 50...60 Hz
Mains Power Consumption:	Typ: 35 VA / 23 W
Mains Power Input Connector:	IEC C14
Mains Fuse:	2 x 3.15 A (or 2 A) time-lag fuse
Dimension and Weight:	483 x 44 x 505 mm ³ (WxHxD), 1 RU (19") approx. 8.6 kg

Specifications are subject to change

Order Information:**HCD-[RF Band(s)]-[IF Band in MHz]-[IF Imp in Ω]-[Options]****SCD-[RF Band(s)]-[IF Band in MHz]-[IF Imp in Ω]-[Options]****Possible Options are:** **FAN** (internal Fan)**VFD** (VFD display, standard with HCD-type converters)**DC15** (DC bias tee on signal input with 15 V DC output)**PLO187** (additional 187 MHz reference signal output)**ALC-BW** (Automatic level control- Filter bandwidth, see product:
Automatic Level Control)**Examples:****HCD-L1-140-50****SCD-L2L2-140-75-FAN-DC15-PLO187****HCD-LL-140-50-FAN-DC15****SCD-LC-140-50-FAN** Combination with of L-Band (Narrowband) Downconverter and
C-Band Satellite Downconverter) with Fan

Satellite Narrowband Downconverter

Indoor Version

S-Band to 725 MHz Downconverter

S-Type (standard version), H-Type (extended temperature range)

Downconverter Type:	SCD-S	
Frequency resolution:	100 kHz	
RF-Input Frequency:	2.3...2.95 GHz	
Conversion Scheme:	Single down-conversion, no frequency inversion	
LO Frequency:	1.55...2.25 GHz	
RF-Input Characteristics:	Impedance:	50 Ω
	Return Loss:	>15 dB (VSWR = 1.22)
	Maximum Aggregate Input Level:	0 dBm
	LO Leakage	<-42 dBm
	RF-Connector	SMA female
IF-Output Characteristics:	Frequency:	700...750 MHz
	Impedance:	50 Ω
	Return Loss:	>15 dB (VSWR = 1.22)
	1 dB Compression Point:	>7 dBm
	IF-Connectors:	SMA female
Transfer Characteristics:	Conversion Gain:	5...35 dB
	Gain-Resolution:	1 dB
	Gain Accuracy:	± 0.2 dB typical (± 0.3 dB max.)
	Gain Stability:	± 0.25 dB/day (constant temperature)
	Amplitude Ripple:	± 0.2 dB / 20 MHz
	IF Output Bandwidth (3 dB):	1 GHz ¹⁾ / 20 MHz
	Noise Figure:	< 12 dB ²⁾
Group Delay (700...750 MHz):	Ripple, Slope:	< 2 ns peak ... peak / 80 MHz
Intermodulation (3rd Order):	-60 dBc max (Δf_{in} : 5 MHz, $P_{out\ ges}$: < -12 Bm) (OIP3 = +15 dBm)	
AM / PM conversion:	0.1° / dB (P_{out} = 0 dBm)	
Phase Noise:	10 Hz	-50 dBc/Hz
	100 Hz	-70 dBc/Hz
	1 kHz	-80 dBc/Hz
	10 kHz	-83 dBc/Hz
	100 kHz	-95 dBc/Hz ¹⁾
	1 MHz	-111 dBc/Hz ¹⁾
Spurious Outputs:	Signal dependent:	<-55 dBc
Frequency Stability:	$\pm 1 \times 10^{-7}$ 0°C ... 50°C with OCXO	
	$\pm 2 \times 10^{-8}$ 0°C ... 50°C (after 10 min warm up)	
	$\pm 1.5 \times 10^{-9}$ per day (fixed temperature after 24 h warm up)	
Test Output: (Microwave Oscillator)	not available	
Temperature Range:	0 °C ... 50 °C operating -30 °C ... 80 °C storage	
Relative Humidity:	<95 % non condensing	
User Interface	LCD, 2 x 40 characters, 4 cursor keys, 2 function keys	
Mains Power Input:	100 ... 240 V AC nominal, 90...264 V AC max, 50...60 Hz	
Mains Power Consumption:	Max: 24 VA / 14 W Typ: 20 VA / 11 W	
Mains Power Input Connector:	IEC C14	
Mains Fuse:	2 x 3.15 A (or 2 A) time-lag fuse	
Dimension and Weight:	483 x 44 x 270 mm ³ (WxHxD), 1 RU (19") approx. 3.5 kg	

Specifications are subject to change

Order Information: SCD-S-725 [IF Band in MHz]-LC

Examples:

SCD-S-725-50-LC

SCD-S-725-75-LC

Satellite Downconverter Narrowband

Indoor Version

140 MHz to 15 MHz Downconverter

S-Type (standard version), H-Type (extended temperature range)

Downconverter Type:	DNC-V		
VHF-Input Frequency:	80...200 MHz		
Conversion Scheme:	Single down-conversion, no frequency inversion		
LO Frequency:	80...200 MHz, Resolution 10 Hz		
RF-Input Characteristics:	Impedance:	50 Ω	
	Return Loss:	>14 dB	
	Maximum Aggregate Input Level:	< -25 dBm (operational)	
		<+10 dBm (damage level)	
	RF-Connector:	BNC female	
IF-Output Characteristics:	Frequency:	0...30 MHz	
	Impedance:	50 Ω	
	Return Loss:	>20 dB	
	1 dB Compression Point:	>10 dBm	
	Output Muting:	>60 dB (during warm-up or during alarm condition)	
	IF-Connectors:	BNC female	
Transfer Characteristics:	Conversion Gain:	45 dB	
	Attenuation Range:	0...30 dB, Step 0.1 dB (Conversion Gain 45...15 dB)	
	Gain Accuracy:	± 1.5 dB	
	Level Stability:	± 0.25 dB/day (constant temperature)	
	Amplitude Ripple:	± 0.25 dB / 20 MHz	
	Noise Figure:	<20 dB	
Internal Filter*:	4 internal filters		
	80...110 MHz		
	110...140 MHz		
	140...170 MHz		
	170...200 MHz		
External Filter:	can be connected through BNC connectors		
	Impedance: 50 Ohms		
Phase Noise:	10 Hz	-80 dBc/Hz	max values
	100 Hz	-100 dBc/Hz	
	1 kHz	-110 dBc/Hz	
	10 kHz	-120 dBc/Hz	
	100 kHz	-125 dBc/Hz ¹⁾	¹⁾ 0°C ... 50°C, outside this temperature range degraded by max 5 dB.
Spurious Outputs:	<-70 dB		
Frequency Stability:	± 1 x 10 ⁻⁷ , 0°C ... 50°C		
	± 2 x 10 ⁻⁸ , 0°C ... 50°C (after 10 min warm up)		
	± 1.5 x 10 ⁻⁹ per day (fixed temperature after 24 h warm up)		
Reference Input:	Frequency:	10 MHz or 5 MHz	
	Level:	-3...10 dBm	
	Modes:	internal, external, auto (senses reference input)	
	Impedance:	50 Ω	
	Connector:	BNC female	
Reference Output:	Frequency:	10 MHz	
	Level:	0 ± 3 dBm	
	Impedance:	50 Ω	
	Connector:	BNC female	
Monitoring and Control Interface:	TCP/IP over Ethernet (10 or 100 Mbps, auto sensing)		
	RS232 or RS422/RS485 (Connectors DSUB09 female) (configurable by software)		
	Mute Input: TTL logic input with internal pull up		
Temperature Range:	0°C ... 50°C operating		
	-30°C ... 80°C storage		
Relative Humidity:	<95 % non condensing		
User Interface:	LCD-Display 2 x 40 characters, 4 cursor keys, 2 function keys		
Mains Power Input:	100 ... 240 V AC nominal, 90...264 V AC max, 50...60 Hz		
Mains Power Consumption:	Max: 33 VA / 20 W		
	Typ: 29 VA / 18 W		
Mains Power Input Connector:	IEC C14		
Mains Fuse:	2 x 3.15 A (or 2 A) time-lag fuse		
Dimension and Weight:	483 x 44 x 270 mm ³ (WxHxD), 1 RU (19")		
	approx. 4.2 kg		

Specifications are subject to change

Order Information:

DNC-V-15-50

Synthesized Block Up- and Downconverter

S, C, X, Ku, K, Ka-Band



The satellite up- and downconverters developed and manufactured by WORK Microwave are designed to meet the requirements of modern satellite transmission, like TV uplink and high speed data networks. Analogue transmission formats are supported as well as digital transmission formats. For many years these devices have been used worldwide in fixed satellite earth stations as well as in satellite news gathering (SNG) vehicles and Fly-Aways and other mobile or portable applications. These kind of converters have been built for more than 1200 times so far. Customers worldwide appreciate their reliability and high level of quality.

4th Generation – still better

The 4th generation, based on our experience and skill, is still better. The synthesizer and oscillator portion in every satellite converter is the most important component because it decides the converter's reliability. For many years WORK Microwave has been developing and manufacturing high sophisticated microwave oscillators and synthesizers which are used in our converter series as well. The new design allows us to reduce the number of components by more than 30%. In addition, significant improvements have been made on circuit design.

This design results in an AC power consumption of typically 35 VA / 27 W. This leads to an even higher reliability and longer life time.

High signal integrity

The extreme low phase noise of the oscillators guarantees an excellent signal quality. Low spurious emissions allow our customers to use the converters also in the environments with demanding requirements, such as high power video uplinks. Sophisticated temperature compensation guarantees the stability over a very wide temperature range.

Block Converter with frequency synthesizer

In contrast to block converters with fixed or switchable LO these converters include a tunable LO with 10 Hz step size. The frequency bandwidth is selected to achieve low spurious emissions. These properties allow wideband frequency coverage with only one unit, where other concepts with fixed block converters require several different block converter modules.

Housing options

The converters normally are delivered without fans and can be operated in environments, where at minimum 1 RU space for natural ventilation is available above each unit. This eliminates the fan as a potential point of failure. For rack installations without any space in between the units a fan within the converter unit is recommended, which forces an airflow from the right side to left side of the units.

The converters can be operated via the push buttons on the front panel using self-explanatory display menus or via remote control (RS232, RS422/485, TCP/IP over Ethernet). Detailed monitoring of the system status and a summary alarm output (dual change over switch contacts) are provided. For the remote control either ASCII string based commands as well as addressable, packet based commands are provided.

Remote monitoring and control through SNMP and a Web browser interface is also available.

Customized products

In addition to standard products WORK Microwave offers custom tailored products and specialized products as follows:

- Modified or smaller housings to fit into your AC power switch on the front panel
- Existing design for mobile and portable applications.
- Different IF or RF frequency bands, Ka-Band (28GHz) version is under development.
- Customized M&C interface and control syntax.
- Extended storage or operating temperature range.
- Military versions for hostile environment (shock, vibration, humidity).

Key features

- Extreme low power consumption maximum 35 VA / 27 W (single band unit) 37 VA / 29 W (triple band units)
- Extreme low phase noise (< -50 dBc/Hz @ 10 Hz)
- Long- term stability 10^{-7} / year
- Output power +10 dBm (1 dB compression point)
- Low spurious emissions < -80 dBm at full gain (high performance series)
- Automatic reference recognition (5 and 10 MHz)
- Digital gain compensation
- Operating temperature range either -30 °C to 60 °C (-22 °F to 140 °F) or 0 °C to 50 °C (32 °F to 122 °F)
- Remote control through RS232, RS422/485 (2-wire or 4-wire) interfaces. Packet command syntax supports RS485 bus systems and allows addressed operation.
- Remote control through Ethernet supporting a TCP/IP command interface, a Web browser interface and SNMP (MIBs are provided).

- RF test output on the front panel (upconverter only)
- AC power switch on the front panel
- Summary alarm output (dual change over switch contacts)
- Transmit mute input
- Optional internal Fan (Option: FAN)
- CE compliant
- **3 years warranty**

Orders information

WORK Microwave offers two series of 19" rack satellite converters, Standard and High Performance. The specifications are the same for both types except the operating temperature range. The High Performance type operates between -30 °C to 60 °C (-22 °F to 140 °F) and the standard type between 0 °C to 50 °C (32 °F to 122 °F). So if you only need units for inside use, the standard unit is perfectly suited for this application.

Open questions, demo units

If you need more information about WORK Microwave's 4th satellite converter generation or if you would like to have demo unit, please contact us via e-mail: sales@work-microwave.de or call us. We are glad to assist you.

Synthesized Block Upconverter

Indoor Version

Single Band Synthesized Block Upconverter, L-Band Input S-Type (standard version), H-Type (extended temperature range)

Upconverter Type:	HSBU-Ku1 / SSBU-Ku1	HSBU-Ku2 / SSBU-Ku2	HSBU-Ku-2-S002 / SSBU-Ku-2-S002	HSBU-Ku4 SSBU-Ku4	HSBU2-Ku2Ku4 SSBU2-Ku2Ku4
RF-Output Frequency:	Ku-Band 12.75...13.25 GHz	Ku-Band 13.75...14.5 GHz	Ku-Band 10.70 ...11.80 GHz 11.65 ...12.75 GHz (automatically switched)	Ku-Band 12.9...13.5 GHz	Ku-Band 13.75 ...14.5 GHz (Ku2) 12.9 ...13.5 GHz (Ku4) (automatically switched)
RF-Output Return Loss:	> 20 dB	> 20 dB	> 20 dB	> 20 dB	> 20 dB
LO-Frequency:	11.8...11.95 GHz 10 Hz steps	12.3...12.75 GHz 10 Hz steps	9.2...11.1 GHz 10 Hz steps	11.95 GHz	12.8 GHz (Ku2) 11.95 GHz (Ku4)
Phase Noise:	10 Hz 100 Hz 1 kHz 10 kHz 100 kHz 1 MHz	-50 -70 -80 -80 -90 -95 ¹⁾ -105 ¹⁾	-50 -70 -80 -80 -90 -95 ¹⁾ -105 ¹⁾	-50 -70 -80 -80 -90 -95 ¹⁾ -105 ¹⁾	-50 -70 -80 -80 -90 -95 ¹⁾ -105 ¹⁾
max. values in dBc/ Hz ¹⁾ 0°C ... 50°C, outside this temperature range degraded by max 5 dB.					
Input Frequency:	0.95...1.45 GHz	1.0...1.75 GHz (1.45...1.75 GHz)	1.5...1.65 GHz	0.95...1.55 GHz	0.95...1.7 GHz
Conversion Scheme:	Single up-conversion, no frequency inversion				

Upconverter Type:	HSBU-K / SSBU-K	HSBU-K1 / SSBU-K1	HSBU-K-2 / SSBU-K-2		
RF-Output Frequency:	K-Band 17.3...18.4 GHz	K-Band 17.3...18.1 GHz	K-Band 17.3...18.1 GHz 17.6...18.4 GHz (automatically switched)		
RF-Output Return Loss:	> 17 dB	> 17 dB	> 17 dB		
LO-Frequency:	15.85...16.65 GHz, 10 Hz steps	16.05...16.35 GHz, 10 Hz steps	16,05...16.65 GHz, 10 Hz steps		
Phase Noise:	10 Hz 100 Hz 1 kHz 10 kHz 100 kHz 1 MHz	-50 -70 -80 -80 -90 -95 ¹⁾ -105 ¹⁾	-50 -70 -80 -80 -90 -95 ¹⁾ -105 ¹⁾		
max. values in dBc/ Hz ¹⁾ 0°C ... 50°C, outside this temperature range degraded by max 5 dB.					
Input Frequency:	1.45 ... 1.75 GHz	1.25 ... 1.75 GHz	1.25 ... 1.75 GHz		
Conversion Scheme:	Single up-conversion, no frequency inversion				

Upconverter Type:	HSBU-Ka-2-S001 / SSBU-Ka-2-S001	HSBU-Ka8 / SSBU-Ka8	HSBU-Ka9 / SSBU-Ka9	HSBU-Ka12 / SSBU-Ka12	
RF-Output Frequency:	Ka-Band 17.7...19.5 GHz 19.4...21.2 GHz (automatically switched)	Ka-Band 22.55 ... 23.15 GHz	Ka-Band 26.3 ... 26.7 GHz	Ka-Band 27.5 ... 28.25 GHz	
RF-Output Return Loss:	> 17 dB	> 17 dB	> 17 dB	> 17 dB	
LO-Frequency:	15.2...18.7 GHz, 10 Hz steps	21.55 GHz fixed	25.3 GHz fixed	26.5 GHz fixed	
Phase Noise:	10 Hz 100 Hz 1 kHz 10 kHz 100 kHz 1 MHz	-50 -70 -80 -86 -91 -105 ¹⁾	-46 -66 -76 -86 -91 -101	-46 -66 -76 -86 -91 -101	
max. values in dBc/ Hz ¹⁾ 0°C ... 50°C, outside this temperature range degraded by max 5 dB.					
Input Frequency:	2.45 ... 2.55 GHz	1.0 ... 1.6 GHz	1.0 ... 1.4 GHz	1.0 ... 1.75 GHz	
Conversion Scheme:	Single up-conversion, no frequency inversion				

Specifications continued next page

Synthesized Block Upconverter

Indoor Version

Single Band Synthesized Block Upconverter, L-Band Input S-Type (standard version), H-Type (extended temperature range)

Specifications continued:

Upconverter Type:	HSBU-Ka4 / SSBU-Ka4				
RF-Output Frequency:	Ka-Band 27.5 ... 31.0 GHz				
RF-Output Return Loss:	> 17 dB				
Phase Noise:	10 Hz 100 Hz 1 kHz 10 kHz 100 kHz 1 MHz	-46 -66 -76 -86 -91 -101			
	max. values in dBc/ Hz ¹⁾ 0°C ...50°C, outside this temperature range degraded by max 5 dB.				
LO2-Frequency:	36.2 ... 39.0 GHz 10 Hz steps				
Intermediate Frequency:	8.0 ... 8.7 GHz				
LO1-Frequency::	9.7 GHz				
Input-Frequency:	1.0 ... 1.7 GHz				
Conversion Scheme:	Dual up-conversion, no frequency inversion				

IF-Input Characteristics:	Impedance: Return Loss: IF-Connectors:	50 Ω >15 dB SMA female
RF-Output Characteristics:	Impedance: 1 dB Compression Point: Output Muting: RF-Connectors:	50 Ω >10 dBm (standard) >20 dBm (for HSBU-Ku-2-S002 / SSBU-Ku-2-S002) >13 dBm (for HSBU-Ka-2-S001 / SSBU-Ka-2-S001) >70 dB (by command or sense input or by alarm condition) SMA female (Standard) K-female (RF Output >18 GHz)
Transfer Characteristics:	Conversion Gain: Attenuation Range: Gain Variation over Temp.: Gain Flatness over Freq.: Gain Flatness over 40 MHz: Gain Stability: Image Rejection: Noise Figure:	30 dB (standard) 40 dB (HSBU/SSBU-Ku-2-S002) 20 dB (HSBU/SSBU Ka4, HSBU/SSBU Ka8) 0...30 dB, 0.1 dB steps (Standard) 0 dB fixed gain (HSBU/SSBU-Ka-2-S001) ±1 dB max ±1.5 dB max. over band (C, X or Ku) ±0.5 dB ±0.25 dB >80 dB <15 dB
Intermodulation (3rd Order):	-36 dBc max (delta f _{in} : 5 MHz, P _{in} : 2 x -20 dBm, P _{out} : 2 x 0 dBm) -36 dBc max (delta f _{in} : 5 MHz, P _{in} : 2 x -10 dBm, P _{out} : 2 x 10 dBm) -36 dBc max (delta f _{in} : 5 MHz, P _{in} : 2 x -7 dBm, P _{out} : 2 x 3 dBm)	(standard) (for HSBU-Ku-2-S002 / SSBU-Ku-2-S002) (for HSBU-Ka-2-S001 / SSBU-Ka-2-S001)
AM / PM conversion:	0.1° / dB (P _{out} = 0 dBm)	
Group Delay (within frequency band):	Ripple, Slope:	< 2 ns peak to peak / 80 MHz
Spurious Outputs:	Signal related: Signal independent:	< - 60 dBc (Δf < 1 MHz), < -70 dBc (Δf ≥ 1 MHz) < - 70 dBm (standard) < - 60 dBm (for HSBU-Ku-2-S002 / SSBU-Ku-2-S002)
Frequency Stability:	± 1 x 10 ⁻⁷ , 0°C ... 50°C ± 2 x 10 ⁻⁸ , 0°C ... 50°C (after 30 min warm up) ± 1.5 x 10 ⁻⁹ per day (fixed temperature after 24 h warm up)	

Specifications continued next page

Synthesized Block Upconverter

Indoor Version

Single Band Synthesized Block Upconverter, L-Band Input S-Type (standard version), H-Type (extended temperature range)

Specifications continued:

Reference Input:	Frequency: 10 MHz or 5 MHz Level: -3...10 dBm Modes: internal, external, auto (senses reference input) Connector: BNC female
Reference Output:	Frequency: 10 MHz Level: 0 ± 3 dBm Connector: BNC female
Monitoring and Control Interface:	Protocol: SNMP Connection: UDP over Ethernet (10 or 100 Mbps, auto sensing), connector RJ-45
	Protocol: HTTP (web browser interface) Connection: TCP/IP over Ethernet (10 or 100 Mbps, auto sensing), connector RJ-45
	Protocol: Multipoint Connection: RS232 or RS422/RS485 (configurable), connector DSUB09 female or TCP/IP over Ethernet (10 or 100 Mbps, auto sensing), connector RJ-45
Alarm Interface: Mute Input:	Alarm: two potential free contacts (DPDT), Mute Input: TTL logic input with internal pull up Connector DSUB09 female
Temperature Range:	HCU : -30°C ... 60°C operating (10 minutes warm up at -30°C) SCU: 0°C ... 50°C operating, - 30°C ... 80°C storage
Relative Humidity:	< 95 % non condensing
User Interface:	SCU: LCD-Display 2 x 40 characters, 4 cursor keys, 4 function keys HCU: VFD-Display 2 x 40 characters, 4 cursor keys, 4 function keys
Mains Power Input:	100 ... 240 V AC nominal, 90...264 V AC max, 50...60 Hz
Mains Power Consumption:	Max: 33 VA / 20 W Typ: 29 VA / 18 W
Mains Power Input Connector:	IEC C14
Mains Fuse:	2 x 3.15 A (or 2 A) time-lag fuse
Dimension and Weight:	483 x 44 x 505 mm ³ (WxHxD), 1 RU (19") approx. 8.4 kg

Specifications are subject to change

Order Information:

**HSBU-[RF Band]-[Options] or
SSBU-[RF Band]-[Options]**

Possible Options are: FAN (internal Fan)
VFD (VFD display, standard with HCU-type converters)

Example: SSBU-K-2

Synthesized Block Downconverter

Indoor Version

Single Band Synthesized Block Downconverter, L-Band Output S-Type (standard version), H-Type (extended temperature range)

Downconverter Type:	HSBD-S / SSBD-S	HSBD-C / SSBD-C	HSBD-X / SSBD-X	HSBD-Ku / SSBD-Ku	HSBD-K / SSBD-K
RF-Input Frequency:	S-Band 2.4 ... 2.7 GHz	C-Band 3.4 ... 4.2 GHz	X-Band 7.25 ... 8.4 GHz	Ku-Band 10.70 ... 12.75 GHz	K-Band 17.3 ... 18.4 GHz
RF-Input Return Loss:	> 20 dB	> 20 dB	> 20 dB	> 20 dB	> 17 dB
LO-Frequency:	3.65 GHz fixed	4.90 ... 5.15 GHz 10 Hz steps	6.3 ... 6.9 GHz 10 Hz steps	9.75 ... 11,3 GHz 10 Hz steps	16.35 ... 16.90 GHz 10 Hz steps
Phase Noise:	10 Hz	-60	-55	-50	-50
	100 Hz	-75	-75	-70	-70
	1 kHz	-85	-85	-80	-80
	10 kHz	-90	-95	-90	-90
	100 kHz	-100 ¹⁾	-100 ¹⁾	-95 ¹⁾	-95 ¹⁾
1 MHz	-112 ¹⁾	-110 ¹⁾	-105 ¹⁾	-105 ¹⁾	
max. values in dBc/ Hz ¹⁾ 0°C ... 50°C, outside this temperature range degraded by max 5 dB.					
IF-Output Frequency:	0.95 ... 1.25 GHz	0.95 ... 1.5 GHz			
Conversion Scheme:	Single downconversion frequency inversion		Single downconversion no frequency inversion		

Downconverter Type:	HSBD-Ka / SSBD-Ka	HSBD-Ka6 / SSBD-Ka6	HSBD-Ka7 / SSBD-Ka7	HSBD-Ka13 / SSBD-Ka13
RF-Input Frequency:	Ka-Band 18.3 ... 20.6 GHz (lower band) 19.7 ... 22.0 GHz (upper band) (automatically switched)	Ka-Band 18.1 ... 21.2GHz	Ka-Band 25.5 ... 27.5GHz	Ka-Band 21.4 ... 22.0GHz
RF-Input Return Loss:	> 17 dB	> 17 dB	> 17 dB	> 17 dB
LO-Frequency:	17.1 ... 20.0 GHz 10 Hz steps	17.15 ... 19.45 GHz 10 Hz steps	24.55 ... 25.75 GHz 10 Hz steps	20.25 GHz fix
Phase Noise:	10 Hz	-47	-46	-46
	100 Hz	-67	-66	-66
	1 kHz	-77	-76	-76
	10 kHz	-87	-86	-86
	100 kHz	-92 ¹⁾	-91	-91
1 MHz	-102 ¹⁾	-101	-101	
max. values in dBc/ Hz ¹⁾ 0°C ... 50°C, outside this temperature range degraded by max 5 dB.				
IF-Output Frequency:	1.2 ... 2 GHz	0.95 ... 1.75 GHz	0.95 ... 1.75 GHz	1.15 ... 1.75 GHz
Conversion Scheme:	Single downconversion, no frequency inversion			

RF-Input Characteristics:	Impedance: 50 Ω Maximum Aggregate Input Level: <-25 dBm (operational) <10 dBm (damage level) LO Leakage: <-80 dBm RF-Connector: SMA female (K-female for HSBD/SSBD Ka7)
IF-Output Characteristics:	Impedance: 50 Ω Return Loss: >20 dB 1 dB Compression Point: >17 dBm (> 10 dBm Ka-band) Output Muting: >60 dB IF-Connectors: SMA female
Transfer Characteristics:	Conversion Gain: 40 dB Standard 30 dB (HSBD/SSBD Ka13) 20 dB (HSBD/SSBD Ka7) Attenuation Range: 0...30 dB, 0.1 dB steps (Standard) Gain Accuracy: ±1.5 dB (± 3 dB Ka-band) (0°C ... 50°C) Gain Flatness over 40 MHz: ± 0.25 dB Image Rejection: >80 dB Noise Figure: <15 dB <11 dB (Conversion Gain 40 dB)
Group Delay:	Ripple, Slope: <2 ns peak to peak / 80 MHz
Intermodulation (3rd Order):	< -50 dBc (Δf _{in} : 5 MHz, P _{out ges} : < +8 dBm) OIP3: +30 dBm (> +20 dBm Ka-band)
AM / PM conversion:	0.1° / dB (P _{out} = 0 dBm)
Spurious Outputs:	Signal dependant: <-70 dBc (Pin < -50 dBm, S-Band) <-55 dBc (<100 kHz offset) Signal independent: <-80 dBm Spurious Reception: <-25 dBc
Frequency Stability:	± 1 x 10 ⁻⁷ 0°C ... 50°C ± 2 x 10 ⁻⁸ 0°C ... 50°C (after 10 min warm up) ± 1.5 x 10 ⁻⁹ per day (fixed temperature after 24 h warm up)

Specifications continued next page

Synthesized Block Downconverter

Indoor Version

Single Band Synthesized Block Downconverter, L-Band Output S-Type (standard version), H-Type (extended temperature range)

Specifications continued:

Reference Input:	Frequency: 10 MHz or 5 MHz Level: -3...10 dBm Modes: internal, external, auto (senses reference input) Impedance: 50 Ω Connector: BNC female
Reference Output:	Frequency: 10 MHz Level: 0 ± 3 dBm Impedance: 50 Ω Connector: BNC female
Test Output LO: (Microwave Oscillator)	Level: -7 ± 3 dBm Impedance: 50 Ω Connector: SMA female
Monitoring and Control Interface:	Protocol: SNMP Connection: UDP over Ethernet (10 or 100 Mbps, auto sensing), connector RJ-45
	Protocol: HTTP (web browser interface) Connection: TCP/IP over Ethernet (10 or 100 Mbps, auto sensing), connector RJ-45
	Protocol: Multipoint Connection: RS232 or RS422/RS485 (configurable), connector DSUB09 female or TCP/IP over Ethernet (10 or 100 Mbps, auto sensing), connector RJ-45
Alarm Interface: Mute Input:	Alarm: two potential free contacts (DPDT), Mute Input: TTL logic input with internal pull up Connector DSUB09 female
Temperature Range:	HSBD: -30°C ... 60°C operating (10 minutes warm up at -30°C) SSBD: 0°C ... 50°C operating -30°C ... 80°C storage
Relative Humidity:	<95 % non condensing
User Interface:	SSBD: LCD-Display 2 x 40 characters, 4 cursor keys, 4 function keys HSBD: VFD-Display 2 x 40 characters, 4 cursor keys, 4 function keys
Mains Power Input:	100 ... 240 V AC nominal, 90...264 V AC max, 50...60 Hz
Mains Power Consumption:	Max: 33 VA / 20 W Typ: 29 VA / 18 W
Mains Power Input Connector:	IEC C14
Mains Fuse:	2 x 3.15 A (or 2 A) time-lag fuse
Dimension and Weight:	483 x 44 x 505 mm ³ (WxHxD), 1 RU (19") approx. 8.2 kg

Specifications are subject to change

Order Information:

**HSBD-[RF Band]-[Options] or
SSBD-[RF Band]-[Options]**

Possible Options are: FAN (internal Fan)
VFD (VFD display, standard with HCU-type converters)
VG (variable Gain)
OD (Outdoor unit)

Example: SSBD-Ku-VG

Synthesized Block Up- and Downconverter Outdoor Version

S-, C-, X- Ku-, K(DBS)-, Ka Band



Ka-band model

These upconverters accept input signals at L-band or Ku-band and provide output signals up to Ka-band (27.5 ... 31 GHz). The usable bandwidth of up to 1600 MHz can be adjusted by a synthesized LO within the overall wide frequency range.

This design allows high flexibility for multicarrier earth station operation, while supporting an optimized wide bandwidth and providing excellent spurious and intermodulation behavior.

The converter units can be mounted close by to outdoor HPAs. A waveguide interface is available for output signals in Ka-band.

For remote control a remote control unit is available.

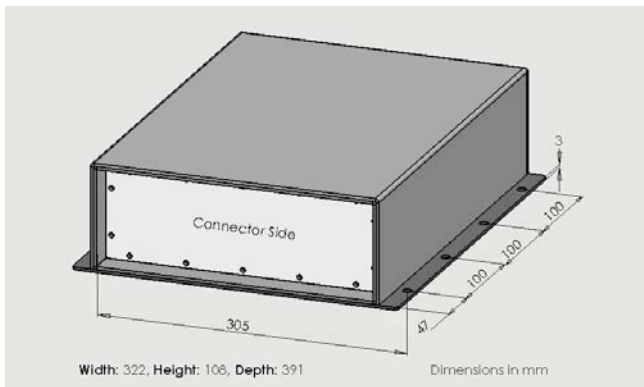

Key features

- Input frequency: L-band or Ku-band
- Synthesized LO allows band selection with typically 10 Hz step size, to adjust the usable output frequency range
- Output power +5 dBm or +10dBm (1 dB compression point)
- L-band, Ku-band input: SMA connector
- Standard output: SMA
- Ka-band output: Waveguide connection or K
- Digital gain compensation
- Reference input 5 or 10 MHz autosensing (Option)
- Operating temperature range -30°C to 60°C (-22°F to 140°F), storage temperature -50°C to 80°C (-58°F to 140°F)
- Remote control through RS232 and RS422/485 (2-wire or 4-wire bus) interfaces
- Packet command syntax supports RS485 bus systems and allows addressed operation
- Summary alarm output (dual change over switch contacts) and transmit mute input
- IP 67 protected housing
- CE compliant
- **3 years warranty**

Synthesized Block Upconverter

Outdoor Version

Single Band Synthesized Block Upconverter, L-Band Input (Ku-band Input) S-Type (standard version), H-Type (extended temperature range)

Upconverter Type:	HSBU-K-OD / SSBU-K-OD	HSBU-K1-OD / SSBU-K1-OD	HSBU-K-2-OD / SSBU-K-2-OD	Other bands
RF-Output Frequency:	K-Band 17.3...18.4 GHz	K-Band 17.3...18.1 GHz	K-Band 17.3...18.1 GHz 17.6...18.4 GHz (automatically switched)	available on request as for HSBU / SSBU Indoor units
RF-Output Return Loss:	> 17 dB	> 17 dB	> 17 dB	
Phase Noise:	10 Hz 100 Hz 1 kHz 10 kHz 100 kHz 1 MHz	-50 -70 -80 -90 -95 ¹⁾ -105 ¹⁾	-50 -70 -80 -90 -95 ¹⁾ -105 ¹⁾	
max. values in dBc/ Hz ¹⁾ 0°C ... 50°C, outside this temperature range degraded by max 5 dB.				
LO-Frequency:	15.85...16.65 GHz, 10 Hz steps	16.05...16.35 GHz, 10 Hz steps	16,05...16.65 GHz, 10 Hz steps	
Input-Frequency:	1.45 ... 1.75 GHz	1.25 ... 1.75 GHz	1.25 ... 1.75 GHz	
Conversion Scheme:	Single up-conversion, no frequency inversion			

Upconverter Type:	HSBU-Ka4-OD	HSBU-Ka1-OD	HSBU-Ka12-OD / SSBU-Ka12-OD	HSBU-Ka-OD-Ku
RF-Output Frequency:	Ka-Band 27.5 ... 31.0 GHz	Ka-Band 27.5 ... 28.6 GHz	Ka-Band 27.5 ... 28.25 GHz	Ka-Band 27.5 ... 30.0 GHz
RF-Output Return Loss:	> 17 dB	> 17 dB	> 17 dB	> 18 dB
Phase Noise:	10 Hz 100 Hz 1 kHz 10 kHz 100 kHz 1 MHz	-46 -66 -76 -86 -91 -101	-46 -66 -76 -86 -91 -101	-47 -67 -77 -87 -92 -102
max. values in dBc/ Hz ¹⁾ 0°C ... 50°C, outside this temperature range degraded by max 5 dB.				
LO2-Frequency:	36.2 ... 39.0 GHz 10 Hz steps	26.05 ... 26.85 GHz 10 Hz steps z	26.5 GHz fixed	15.7 ... 16.6 GHz 10 Hz steps
Intermediate Frequency:	8.0 ... 8.7 GHz	-	-	-
LO1-Frequency:	9.7 GHz	-	-	-
Input-Frequency:	1.0 ... 1.7 GHz	1.45 ... 1.75 GHz	1.0 ... 1.75 GHz	11.8 ... 13.4 GHz
Conversion Scheme:	Dual up-conversion, no frequency inversion	Single up-conversion, no frequency inversion		

IF-Input Characteristics:	Impedance: Return Loss: Connector Type::	50 Ω >15 dB SMA female
RF-Output Characteristics:	Connection Type: 1 dB Gain Compression Point: Output Muting:	SMA female (Standard) Waveguide WR28, Flange PBR320, Threads M3 (RF Output > 26.5 GHz) K female (RF Output > 18 GHz, RF Output > 26.5 GHz Option K) >5 dBm >10 dBm (HSBU-Ka4-OD) >60 dB (by command or sense input or by alarm condition)
Transfer Characteristics:	Conversion Gain: Attenuation Range: Gain Accuracy: Level Stability: Amplitude Response: Image Rejection: Noise Figure:	30 dB (Standard) 20 dB (HSBU-Ka-OD-Ku, HSBU-Ka4-OD) 0 ... 30 dB, 0.1 dB steps (Standard) 0 dB fixed gain (HSBU-Ka-OD-Ku) ±1.5 dB ±0.25 dB/day (constant temperature) ±0.25 dB / ±20 MHz >80 dB <15 dB
Group Delay (± 36 MHz):	Ripple, Slope:	<2 ns peak to peak / 80 MHz
Intermodulation (3rd Order):		-36 dBc max (delta f: 5 MHz, P _{out} : 2 x 0 dBm)
Spurious Outputs:	Signal related: Signal independent:	<-60 dBc <-70 dBm
Frequency Stability:		± 1 x 10 ⁻⁷ , 0°C ... 50°C ± 2 x 10 ⁻⁸ , 0°C ... 50°C (after 30 min warm up) ± 1.5 x 10 ⁻⁹ per day (fixed temperature after 24 h warm up)

Specifications continued next page

Synthesized Block Upconverter

Outdoor Version

Single Band Synthesized Block Upconverter, L-Band Input (Ku-band Input) S-Type (standard version), H-Type (extended temperature range)

Specifications continued:

Reference Input (Option RIN):	Frequency: 10 MHz or 5 MHz Level: -3 ... 10 dBm Modes: internal, external, auto (senses reference input) Connector: SMA female
Monitoring and Control Interface:	RS232 or RS422/RS485 Alarm Output: Two potential free contacts (DPDT) 24 V DC output: max 0,3 A 6,5 V DC output: max 0,2 A Mute Input: TTL logic input with internal pull up (Connector type: MIL-C-26482: MS 3120 E 14-19 S)
Temperature Range:	HCU : -30°C ... 60°C operating (10 minutes warm up at -30°C) -30°C ... 80°C storage
Relative Humidity:	<100 %
Mains Power Input:	100 ... 240 V AC nominal, 90...264 V AC max, 50...60 Hz
Mains Power Consumption:	Max: 40 VA / 25 W (single converters) Typ: 30 VA / 20 W (single converters)
Mains Power Input Connector:	Amphenol C16-1 (3+PE) male
Dimension and Weight:	322 x 108 x 391 mm ³ (WxHxD) approx. 8.4 kg
Degree of Protection:	IP 67 (acc. IEC 529)

Specifications are subject to change

Order Information:

HSBU-Ka-OD-[Options] or **HSBU-Ka1-OD-[Options]** L-Ka Band Converter
HSBU-Ka-OD-Ku-[Options] Ku-Ka Band Converter

Possible Options are: RIN (external Reference Input)
K (RF Output K Connector instead of Waveguide)

Examples:
HSBU-Ka-OD-Ku-RIN

Synthesized Block Downconverter

Outdoor Version

Single Band Synthesized Block Downconverter, L-Band Output S-Type (standard version), H-Type (extended temperature range)

Downconverter Type:	HSBD-Ku-OD / SSBD-Ku-OD	Other bands	HSBD-Ka7-OD / SSBD-Ka7-OD	HSBD-Ka13-OD / SSBD-Ka13-OD
RF-Input Frequency:	Ku-Band 10.70 ... 12.75 GHz	available on request as for HSBU / SSBU Indoor units	Ka-Band 25.5 ... 27.5GHz	Ka-Band 21.4 ... 22.0GHz
RF-Input Return Loss:	> 20 dB		> 17 dB	> 17 dB
LO-Frequency:	9.75 ... 11,3 GHz 10 Hz steps		24.55 ... 25.75 GHz 10 Hz steps	20.25 GHz fixed
Phase Noise:	10 Hz 100 Hz 1 kHz 10 kHz 100 kHz 1 MHz	-50 -70 -80 -90 -95 ¹⁾ -105 ¹⁾	-46 -66 -76 -86 -91 -101	-46 -66 -76 -86 -91 -101
max. values in dBc/Hz ¹⁾ 0°C ... 50°C, outside this temperature range degraded by max 5 dB.				
IF-Output Frequency:	0.95 ... 1.5 GHz		0.95 ... 1.75 GHz	1.15 ... 1.75 GHz
Conversion Scheme:	Single downconversion, no frequency inversion			
RF-Input Characteristics:	Impedance: Maximum Aggregate Input Level: LO Leakage: RF-Connector:	50 Ω <-25 dBm (operational) <10 dBm (damage level) <-80 dBm SMA female (Standard) K female (Input frequency > 18 GHz)		
IF-Output Characteristics:	Impedance: 1 dB Compression Point: Output Muting: IF-Connectors:	50 Ω >17 dBm >60 dB SMA female or N female		
Transfer Characteristics:	Conversion Gain: Attenuation Range: Gain Accuracy: Gain Flatness over 40 MHz: Image Rejection: Noise Figure:	40 dB (Standard) 30 dB (HSBD/SSBD Ka13) 20 dB (HSBD/SSBD Ka7) 0...30 dB, 0,1 dB steps (Standard) ± 2 dB (0°C ... 50 °C) ± 0,25 dB >80 dB <15 dB		
Group Delay:	Ripple, Slope:	<2 ns peak to peak / 80 MHz		
Intermodulation (3rd Order):	< -60 dBc (Δf_{in} : 5 MHz, P_{out} : < 2x 0 dBm, Att = 0 dB)			
AM / PM conversion:	0,1° / dB (P_{out} = 0 dBm)			
Spurious Outputs:	Signal dependant: Signal independent:	<-70 dBc (Pin <-50 dBm, S-Band) <-55 dBc (<100 kHz offset) <-80 dBm		
Frequency Stability:	± 1 x 10 ⁻⁷ , 0°C ... 50°C ± 2 x 10 ⁻⁸ , 0°C ... 50°C (after 10 min warm up) ± 1,5 x 10 ⁻⁹ per day (fixed temperature after 24 h warm up)			
Reference Input (Option RIN):	Frequency: Level: Modes: Impedance: Connector:	10 MHz or 5 MHz -3...10 dBm internal, external, auto (senses reference input) 50 Ω SMA female		
Monitoring and Control Interface:	RS232 or RS422/RS485 Alarm Output: Two potential free contacts (DPDT) 24 V DC output: max 0,3 A 6,5 V DC output: max 0,2 A Mute Input: TTL logic input with internal pull up (Connector type: MIL-C-26482: MS 3120 E 14-19 S)			
Temperature Range:	HCU : -30°C ... 60°C operating (10 minutes warm up at -30°C) -30°C ... 80°C storage			
Relative Humidity:	<100 %			
Mains Power Input:	100 ... 240 V AC nominal, 90...264 V AC max, 50...60 Hz			
Mains Power Consumption:	Max: 40 VA / 25 W (single converters) Typ: 30 VA / 20 W (single converters)			
Mains Power Input Connector:	Amphenol C16-1 (3+PE) male			
Dimension and Weight:	322 x 108 x 391 mm ³ (WxHxD) approx. 8,4 kg			
Degree of Protection:	IP 67 (acc. IEC 529)			

Specifications are subject to change

Order Information:

HSBD-Ka7-OD-[Options] or HSBDU-Ka7-OD-[Options] Ka-L Band Converter
Possible Options are: RIN (external Reference Input)

Examples:

HSBD-Ka13-OD-RIN

L-Band Block Upconverter

C, X, Ku, K-Band
Also available as Outdoor Version



SBU-Type

Key features HBU/SBU-Type

- Low phase noise
- Adjustable attenuator (typ. range: 0 ... 20 dB, 0.1 dB step size)
- Output power +10 dBm (1 dB compression point)
- Low spurious emissions
- Internal OCXO with long term stability 10^{-7} / year
- External reference input 5 or 10 MHz
- Local control through push buttons on front panel and display menu
- Stored alarms with time stamps
- Remote control through RS232, RS422/485 (2-wire or 4-wire) interfaces. Packet command syntax supports RS485 bus systems and allows addressed operation.
- Remote control through Ethernet supporting a TCP/IP command interface, a Web browser interface and SNMP (MIBs are provided) (Indoor Version only).
- Summary alarm output (DPDT)
- Low power consumption typ. less than 15 W
- CE compliant
- **3 years warranty**



SBUL-Type

Key features HBUL/SBUL-Type

- Low phase noise
- Adjustable attenuator (range: 0 ... 19 dB, 1 dB step size) through attenuator selector on front panel
- Output power +10 dBm (1 dB compression point)
- Low spurious emissions
- Internal OCXO with long term stability 10^{-7} / year
- External reference input 5 or 10 MHz
- L-Band monitor output on front panel (Option IFT)
- Summary alarm output (DPDT)
- RS232 diagnostic interface
- Low power consumption typ. less than 13 W
- CE compliant
- **3 years warranty**

L-Band Block Upconverter

L-Band to C, X, Ku, K-Band

Upconverter Type:	HBU/SBU/SBUL-C	HBU/SBU/SBUL-X	HBU/SBU/SBUL-Ku1 - HBU/SBU/SBUL-Ku3	HBU/SBU/SBUL-K1	HBU/SBU-K-2
RF-Output Frequency:	C-Band 5.85 ... 6.45 GHz	X-Band 7.90 ... 8.40 GHz	Ku-Band Ku1: 13.75 ... 14.50 GHz Ku3: 12.75 ... 13.50 GHz	K-Band 17.30 ... 18.10 GHz	K-Band 17.30 ... 17.95 GHz 17.75 ... 18.40 GHz
LO Frequency:	4.90 GHz	6.95 GHz	12.80 GHz (Ku1) 11.80 GHz (Ku3)	16.35 GHz	15.90 / 16.35 GHz switchable
Phase Noise:	10 Hz 100 Hz 1 kHz 10 kHz 100 kHz 1 MHz	-58 -70 -80 -89 -95 -115	-58 -70 -80 -85 -93 -120	-58 -72 -78 -88 -110 -120	-58 -72 -76 -85 -93 -115
max values in dBc/Hz					
IF-Input Frequency	950 ... 1550 MHz	950 ... 1450 MHz	950 ... 1700 MHz	950 ... 1750 MHz	1400 ... 2050 MHz
Conversion Scheme:	Block up conversion, no frequency inversion				
IF-Input Characteristics:	Impedance: 50 Ω Return Loss: >18 dB Connector: SMA female (Indoor Version) N female (Outdoor Version)				
IF-Monitor (Option IFT):	Signal level in reference to input: -20 dB Impedance: 50 Ω Connector: SMA (female)				
RF-Output Characteristics:	Impedance: 50 Ω Return Loss: >18 dB 1 dB Compression Point: >10 dBm Output Muting: >75 dB (by command or sense input or by alarm condition) Connectors: SMA (female)				
Transfer Characteristics:	Max Conversion Gain: 35 dB Attenuation range: 0...20 dB, 0.1 dB steps (HBU/SBU) 0...19 dB, 1 dB steps (HBUL/SBUL) Gain Variation over Temp.: ±1 dB max Gain Flatness over Freq.: ±1.5 dB max. over band Gain Flatness over 40 MHz: ±0.5 dB Image Rejection: >80 dB Noise Figure: <15 dB				
Group Delay:	Ripple, Slope: <1 ns peak-peak / 80 MHz				
Spurious Outputs:	Signal related: <-65 dBc Signal independent: <-85 dBm				
Intermodulation (3rd Order):	<-53 dBc (two CW signal input, Δf _{in} : 5 MHz, P _{in} 2 x -33 dBm, P _{out} : 2 x -8 dBm)				
Internal frequency Stability:	± 1 x 10 ⁻⁷ , 0°C ... 50°C ± 2 x 10 ⁻⁸ , 0°C ... 50°C (after 30 min warm up) ± 1.5 x 10 ⁻⁹ per day (fixed temperature after 24 h warm up)				
Reference Input:	Frequency: 5 or 10 MHz sine wave Level: 5 dBm ± 5 dBm Modes: auto Connector: BNC				Indoor Version only
Monitoring and Control Interface (HBU/SBU only):	Protocol: SNMP Connection: UDP over Ethernet (10 or 100 Mbps, auto sensing), connector RJ-45				Indoor Version HBU/SBU only
	Protocol: HTTP (web browser interface) Connection: TCP/IP over Ethernet (10 or 100 Mbps, auto sensing), connector RJ-45				Indoor Version HBU/SBU only
	Protocol: Multipoint packet format commands Connection: RS232 or RS422/RS485 (configurable), connector DSUB09 female or TCP/IP over Ethernet (10 or 100 Mbps, auto sensing), connector RJ-45				Indoor Version HBU/SBU only
Diagnostic Interface (HBUL/SBUL only):	RS232, connector DSUB09 female				Indoor Version HBUL/SBUL only
Alarm Interface:	Alarm: two potential free contacts (DPDT), Connector DSUB09 female				Indoor Version
Combined Monitoring and Control Interface and Alarm Interface:	RS232 or RS422/RS485, Multipoint packet format commands Alarm output: Two potential free contacts (DPDT) 24 V DC output: max 0,3 A 6,5 V DC output: max 0,2 A Mute Input: TTL logic input with internal pull up Connector type: MIL-C-26482: MS 3120 E 14-19 S				Outdoor Version
Temperature Range:	HCU: -30°C ... 60°C operating (10 minutes warm up at -30°C) SCU: 0°C ... 50°C operating, -30°C ... 80°C storage				
Relative Humidity:	< 95 % non condensing				Indoor Version
	< 100 %				Outdoor Version

Specifications continued next page

L-Band Block Upconverter

L-Band to C, X, Ku, K-Band

Specifications continued:

User Interface SBU:	LCD-Display 2 x 40 characters, 4 cursor keys, 4 function keys VFD-Display 2 x 40 characters, 4 cursor keys, 4 function keys (HBU, option: VFD for SBU)	Indoor Version
User Interface SBUL:	Attenuator selector on front panel	Indoor Version
Mains Power Input:	100 ... 240 V AC nominal, 90...264 V AC max, 50...60 Hz	
Mains Power Consumption:	Max: 25 VA / 15 W	
Mains Power Input Connector:	IEC C14	Indoor Version
	Amphenol C16-1 (3+PE) male	Outdoor Version
Mains Fuse:	2 x 2 A time-lag fuse	Indoor Version only
Dimension and Weight:	483 x 44 x 270 mm ³ (WxHxD), 1 RU (19") approx. 6 kg	Indoor Version
	402 x 111 x 391 mm ³ (WxHxD) approx. 8 kg	Outdoor Version

Specifications are subject to change

Order Information:

HBU/SBU-[RF Band]-[Options] or HBUL/SBUL-[RF Band]-[Options]

Possible Options are: VFD (VFD display for SBU)
IFT (IF Monitor on Frontpanel)
OD (Outdoor Unit, HBU only)
FAN (Indoor Unit only)

Example: SBU-Ku1 (Ku-Band 1)

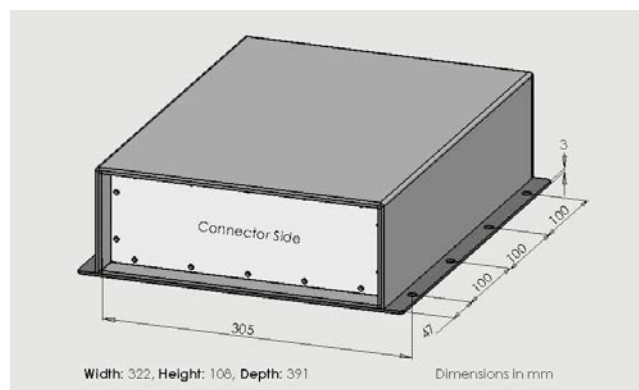

Dimensions of Outdoor Housing

L-Band Block Downconverter

C, X, Ku-Band Input, L-Band Output
Also available as Outdoor Version



SBD-Type

Key features HBD/SBD-Type

- Low phase noise
- Adjustable attenuator (range: 0...20 dB, 0.1 dB step size)
- Output power +10 dBm (1 dB compression point)
- Low spurious emissions
- Internal OCXO with long term stability 10^{-7} / year
- External reference input 5 or 10 MHz
- Local control through push buttons on front panel and display menu
- Stored alarms with time stamps
- Remote control through RS232, RS422/48 (2-wire or 4-wire) interfaces. Packet command syntax supports RS485 bus systems and allows addressed operation.
- Remote control through Ethernet supporting a TCP/IP command interface, a Web browser interface and SNMP (MIBs are provided) (Indoor Version only).
- Summary alarm output (DPDT)
- Low power consumption typ. less than 15 W
- CE compliant
- **3 years warranty**



SBDL-Type

Key features HBDL/SBDL-Type

- Low phase noise
- Adjustable attenuator (range: 0...19 dB, 1 dB step size) through attenuator selector on front panel
- Output power +10 dBm (1 dB compression point)
- Low spurious emissions
- Internal OCXO with long term stability 10^{-7} / year
- External reference input 5 or 10 MHz
- L-Band monitor output on front panel
- Summary alarm output (DPDT)
- RS232 diagnostic interface
- Low power consumption typ. less than 13 W
- CE compliant
- **3 years warranty**

L-Band Block Downconverter

C, X, Ku, K-Band to L-Band

Downconverter Type:	HBD/SBD/SBDL-C	HBD/SBD/SBDL-X	HBD/SBD/SBDL-Ku1	HBD/SBD/SBDL-Ku2	HBD/SBD/SBDL-Ku3
RF-Input Frequency:	C-Band 3.4 ... 4.2 GHz	X-Band 7.25 ... 7.75 GHz	Ku-Band 10.95 ... 11.7 GHz	Ku-Band 10.7 ... 11.7 GHz	Ku-Band 11.7 ... 12.75 GHz
LO Frequency:	5.15 GHz	6.30 GHz	10.00 GHz	9.75 GHz	10.75 GHz
Phase Noise:	10 Hz 100 Hz 1 kHz 10 kHz 100 kHz 1 MHz	-58 -70 -80 -89 -95 -115	-58 -70 -80 -89 -95 -115	-54 -66 -76 -85 -93 -115	-54 -66 -76 -85 -93 -115
	max values in dBc/Hz				
IF-Output Frequency:	950 ... 1750 MHz	950 ... 1450 MHz	950 ... 1700 MHz	950 ... 1950 MHz	950 ... 2000 MHz
Conversion Scheme:	frequency inversion	no frequency inversion			

Downconverter Type:	SBD2/SBDL2-Ku2Ku3 Dual Channel Converter, including one RF input with signal splitter, two IF Outputs		
RF-Input Frequency:	Ku-Band 10.70 ... 11.70 GHz	Ku-Band 11.70 ... 12.75 GHz	
LO Frequency:	9.75 GHz	10.75 GHz	
Phase Noise:	10 Hz 100 Hz 1 kHz 10 kHz 100 kHz 1 MHz	-54 -66 -76 -85 -93 -115	-54 -66 -76 -85 -93 -115
	max values in dBc/Hz		
IF-Output Frequency:	950 ... 1950 MHz	950 ... 2000 MHz	
Conversion Scheme:	no frequency inversion		

RF-Input Characteristics:	Impedance: 50 Ω Return Loss: >18 dB Maximum Aggregate Input Level: -25 dBm (operational) 5 dBm (damage level) LO Leakage: <-80 dBm max. RF-Connector: SMA female	
IF-Output Characteristics:	Impedance: 50 Ω Return Loss: >18 dB 1 dB Compression Point: >17 dBm IF-Connectors: SMA female (Indoor Version) N female (Outdoor Version)	
Transfer Characteristics:	Max Conversion Gain: 35 dB Attenuation range: 0...20 dB, 0.1 dB steps (HBD/SBD) 0...19 dB, 1 dB steps (HBDL/SBDL) Gain Accuracy: ±1.5 dB (0°C ... 50 °C) Gain Variation over Temp.: ±1 dB Gain Flatness over Freq.: ±1.5 dB over band Gain Flatness over 40 MHz: ±0.5 dB Image Rejection: >80 dB Noise Figure: <11 dB	
Group Delay:	Ripple, Slope: <1 ns peak-peak / 80 MHz	
Spurious Outputs:	Signal related: <-65 dBc Signal independent: <-75 dBm	
Intermodulation (3rd Order):	<-60 dBc (two CW signal input, Δf _{in} : 5 MHz, P _{in} 2 x 0 dBm, Att=0 dB)	
Internal frequency Stability:	± 1 x 10 ⁻⁷ , 0°C ... 50°C ± 2 x 10 ⁻⁸ , 0°C ... 50°C (after 30 min warm up) ± 1.5 x 10 ⁻⁹ per day (fixed temperature after 24 h warm up)	
Reference Input:	Frequency: 5 or 10 MHz sine wave Level: 5 dBm ± 5 dBm Modes: auto Connector: BNC	Indoor Version only
Monitoring and Control Interface (HBU/SBU only):	Protocol: SNMP Connection: UDP over Ethernet (10 or 100 Mbps, auto sensing), connector RJ-45	Indoor Version HBU/SBU only
	Protocol: HTTP (web browser interface) Connection: TCP/IP over Ethernet (10 or 100 Mbps, auto sensing), connector RJ-45	Indoor Version HBU/SBU only
	Protocol: Multipoint packet format commands Connection: RS232 or RS422/RS485 (configurable), connector DSUB09 female or TCP/IP over Ethernet (10 or 100 Mbps, auto sensing), connector RJ-45	Indoor Version HBU/SBU only

Specifications continued next page

L-Band Block Downconverter

C, X, Ku, K-Band to L-Band

Specifications continued:

Diagnostic Interface (HBUL/SBUL only):	RS232, connector DSUB09 female	Indoor Version HBUL/SBUL only
Alarm Interface:	Alarm: two potential free contacts (DPDT), Connector DSUB09 female	Indoor Version
Combined Monitoring and Control Interface and Alarm Interface:	RS232 or RS422/RS485, Multipoint packet format commands Alarm output: Two potential free contacts (DPDT) 24 V DC output: max 0,3 A 6,5 V DC output: max 0,2 A Mute Input: TTL logic input with internal pull up Connector type: MIL-C-26482: MS 3120 E 14-19 S	Outdoor Version
Temperature Range:	HCU: -30°C ... 60°C operating (10 minutes warm up at -30°C) SCU: 0°C ... 50°C operating, - 30°C ... 80°C storage	
Relative Humidity:	< 95 % non condensing	Indoor Version
	< 100 %	Outdoor Version
User Interface SBU:	LCD-Display 2 x 40 characters, 4 cursor keys, 4 function keys VFD-Display 2 x 40 characters, 4 cursor keys, 4 function keys (HBU, option: VFD for SBU)	Indoor Version
User Interface SBUL:	Attenuator selector on front panel	Indoor Version
Mains Power Input:	100 ... 240 V AC nominal, 90...264 V AC max, 50...60 Hz	
Mains Power Consumption:	Max: 25 VA / 15 W	
Mains Power Input Connector:	IEC C14	Indoor Version
	Amphenol C16-1 (3+PE) male	Outdoor Version
Mains Fuse:	2 x 3.15 A (or 2 A) time-lag fuse	Indoor Version only
Dimension and Weight:	483 x 44 x 310 mm ³ (WxHxD), 1 RU (19") approx. 6 kg	Indoor Version
	402 x 111 x 391 mm ³ (WxHxD) approx. 8 kg	Outdoor Version

Specifications are subject to change

Order Information:

HBD/SBD-[RF Band]-[Options] or HBDL/SBDL-[RF Band]-[Options]

Possible Options are: VFD (VFD display for SBD)
OD (Outdoor Unit, HBD only)

Example: SBD-Ku1 (Ku-Band 1)

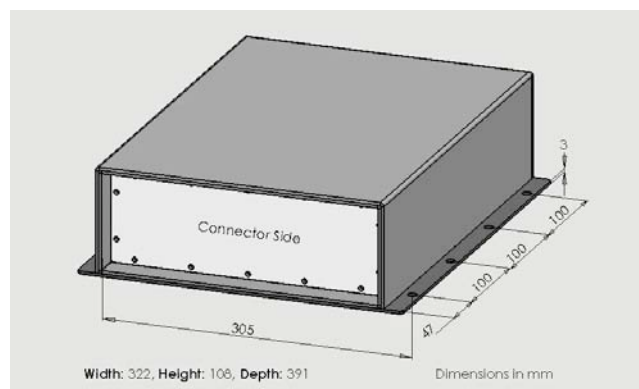

Dimensions of Outdoor Housing

Narrowband Block Downconverter

Indoor Version

Block Downconverter C-Band Input, L-Band Output, Fixed Gain

Downconverter Type:	BD-C	BD-X
RF-Input Frequency:	3.5...3.7 GHz	7.9...8.4 GHz
Conversion Scheme:	Single down-conversion, frequency inversion	Single down-conversion, no frequency inversion
LO Frequency:	5.154 GHz	5.75 GHz
Phase Noise:	10 Hz: -62 dBc/Hz 100 Hz: -83 dBc/Hz 1 kHz: -89 dBc/Hz 10 kHz: -101 dBc/Hz 100 kHz: -104 dBc/Hz ¹⁾ 1 MHz: -111 dBc/Hz ¹⁾	-56 dBc/Hz -76 dBc/Hz -86 dBc/Hz -96 dBc/Hz -101 dBc/Hz ¹⁾ -111 dBc/Hz ¹⁾
	max values in dBc/Hz ¹⁾ 0°C ... 50°C, outside this temperature range degraded by max 5 dB.	
RF-Input Characteristics:	Impedance: 50 Ω Return Loss: >20 dB (VSWR = 1.22) Maximum Aggregate Input Level: <-17 dBm LO Leakage: <-80 dBm RF-Connector: SMA female	
IF-Output Characteristics:	Frequency: 1454...1654 MHz (BD-C) 2150...2650 MHz (BD-X) Impedance: 50 Ω Return Loss: >15 dB 1 dB Compression Point: >19 dBm IF-Connectors: SMA female	
Transfer Characteristics:	Conversion Gain: 35 +/-2 dB (within the operating temperature range) (BD-C) 15 +/-2 dB (within the operating temperature range) (BD-X) Level Stability: ±0.25 dB/day (constant temperature) Amplitude Ripple: ±0.2 dB / 20 MHz Image Rejection: >80 dB Noise Figure: <11 dB	
Group Delay (1454...1654 MHz):	Ripple, Slope: <1 ns peak to peak / 80 MHz	
Intermodulation (3rd Order):	-60 dBc max (Δf_{im} : 5 MHz, $P_{out\ ges}$: < 3 dBm)	
AM / PM conversion:	0.1° / dB (P_{out} = 0 dBm)	
Spurious Outputs:	Signal independent: < -70 dBc < -80 dBm	
Frequency Stability:	± 1 x 10 ⁻⁷ , 0°C ... 50°C ± 2 x 10 ⁻⁸ , 0°C ... 50°C (after 10 min warm up) ± 1.5 x 10 ⁻⁹ per day (fixed temperature after 24 h warm up)	
Reference Input:	Frequency: 10 MHz or 5 MHz Level: -5...10 dBm Modes: auto (senses reference input) Connector: BNC female	
Reference Output:	Frequency: 10 MHz Level: 0 ± 3 dBm Connector: BNC female	
Test Output (Microwave Oscillator):	5.154 GHz -7 ± 3 dBm SMA female	
Temperature Range:	0°C ... 50°C operating -30°C ... 80°C storage	
Relative Humidity:	<95 % non condensing	
Mains Power Input:	100 ... 240 V AC nominal, 90...264 V AC max, 50...60 Hz	
Mains Power Consumption:	Max: 19 VA / 13 W Typ: 16 VA / 10 W	
Mains Power Input Connector:	IEC C14	
Mains Fuse:	2.0 A time-lag fuse	
Dimension and Weight:	483 x 44 x 270 mm ³ (WxHxD), 1 RU (19") approx. 3 kg	

Specifications are subject to change

Order Information: **BD-C**
 BD-X

Satellite Block-Upconverter (mini-buc)

Single / Dual / Triple Band
L-Band to C, X, Ku-Band

Modular concept with arbitrary combinations of output frequencies

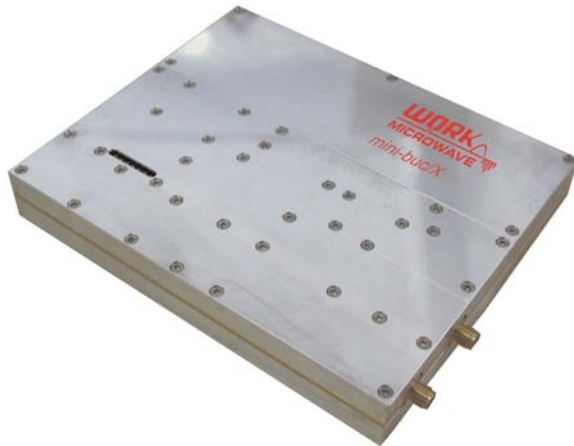

Module
Size: 140x100x17 mm
Weight: 400 g

(Rack Mount- and Outdoor-
Housings are also available)

The mini-buc series of WORK Microwave sets higher standards in modern block converter technology. The usage of integrated circuits provides a most reliable and extremely compact design with very low power consumption and good phase noise. DROs and other critical parts were replaced by MMICs. All mini-bucs are equipped with internal gain control. A built in microcontroller provides an interface to external M&C systems.

Due to the lightweight rugged design, non sensitive against shock and vibrations, these BUCs can be implemented almost everywhere, e.g. in TWTAs and SSPAs for mobile Land, Sea and Airborne systems. They can be used in satellite news gathering (SNG) terminals as well as mobile satellite communication equipment (Fly-Aways).

19" Rack Mount Housings

WORK Microwave's mini-bucs are also available within a standard 19" rack mount housing for easy rack integration.

Outdoor Housings

The mini-bucs are also available within an outdoor housing, which can be mounted directly at the antenna.

Key features

- High integrated MMIC technology
- Low phase noise
- Optional OCXO with long term stability 10^{-7} / year (with separate module SMBU/HMBU-OCXO)
- Output power +10 dBm (1 dB compression point)
- Low spurious emissions
- Low power consumption typ. less than 6 W
- Operating temperature range up to -30°C to +60°C
- Reference input through IF interface (standard) or MMCX Connector (option RIN)
- Remote control through RS422/485 (RS 232 option), (with separate module SMBU/HMBU-OCXO RS232 or RS422/485)
- Packet command syntax supports 2-wire or 4-wire bus systems and allows addressed operation
- Summary alarm output (DPDT) (with separate module SMBU/HMBU-OCXO)
- Transmit mute input
- Adjustable gain control (range: 20 dB)
- Can be cascaded to multi converter configurations
- High reliability, Low cost

Satellite Block-Upconverter (mini-buc)

Single / Dual / Triple Band
L-Band to C, X, Ku-Band

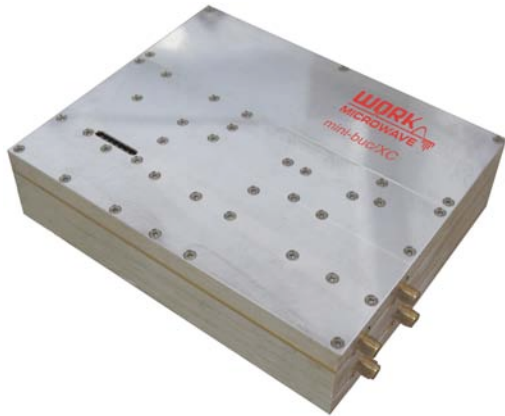

Dual band mini-buc:
Size: 140x100x34 mm
Weight: 800 g

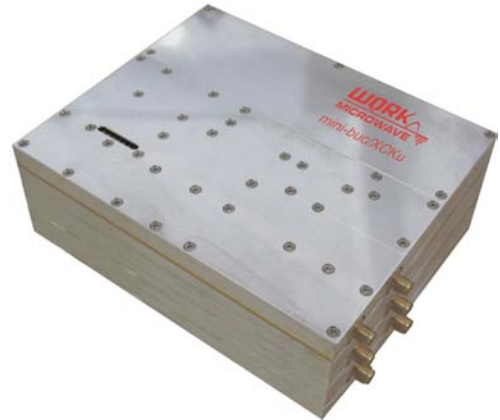

Triple band mini-buc:
Size: 140x100x51 mm
Weight: 1200 g

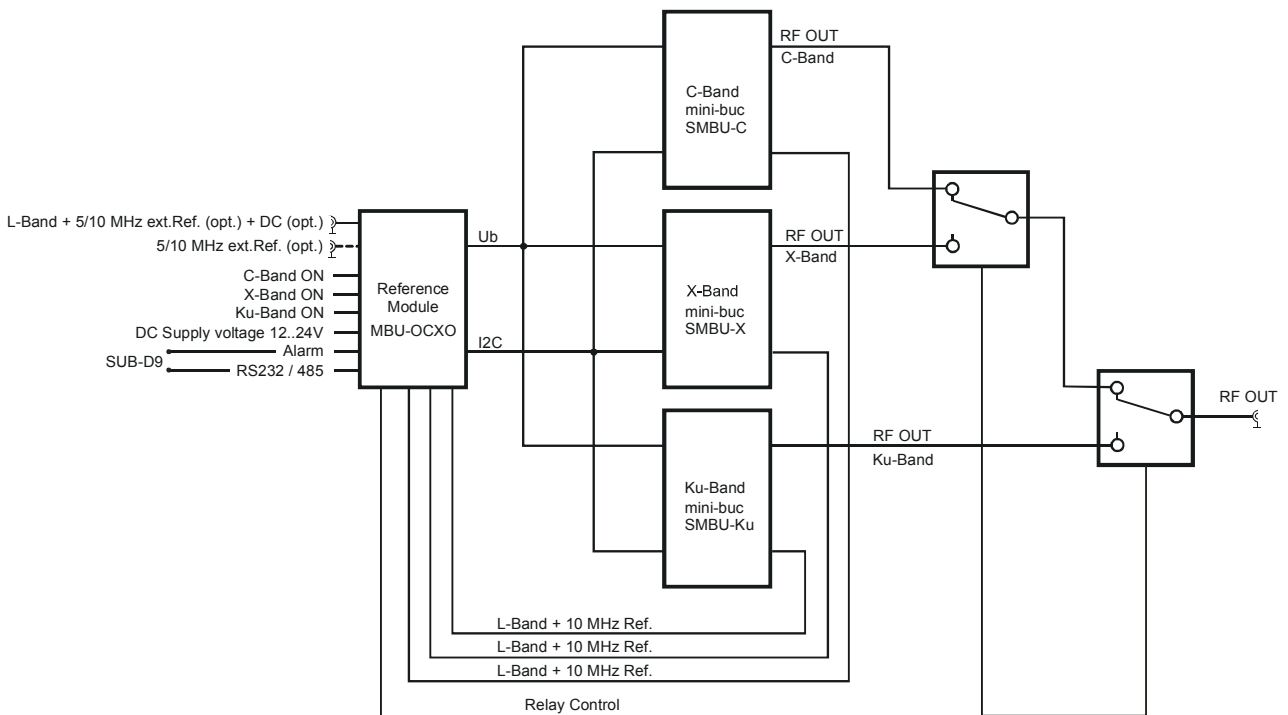

Block diagram of Triple band configuration with reference module

Satellite Block-Upconverter (mini-buc)

Modules

Single / Dual / Triple Band L-Band to C, X, Ku-Band
 S-Type (standard version), H-Type (extended temperature range)

Single Band Type:	SMBU-C, SMBU-X, SMBU-Ku or HMBU-C, HMBU-X, HMBU-Ku		
Dual Band Type:	SMBU-CX, SMBU-CKu, SMBU-XKu or HMBU-CX, HMBU-CKu, HMBU-XKu ¹⁾		
Triple Band Type:	SMBU-CXKu or HMBU-CXKu ¹⁾		
RF-Output Frequency:	C-Band 5.850...6.450 GHz	X-Band 7.9...8.4 GHz	Ku-Band Ku1: 13.75...14.50 GHz Ku3: 12.75...13.50 GHz
LO Frequency:	4.9 GHz	6.95 GHz	12.8 GHz (Ku1) 11.8 GHz (Ku3)
Phase Noise:	10 Hz 100 Hz 1 kHz 10 kHz 100 kHz 1 MHz	-58 -70 -80 -89 -95 -115	-58 -70 -80 -89 -95 -115
	max values in dBc/Hz		
IF-Input Frequency	950 ... 1550 MHz	950 ... 1450 MHz	950 ... 1700 MHz
Conversion Scheme:	Block up conversion, no frequency inversion		
IF-Input Characteristics:	Impedance: 50 Ω Return Loss: >18 dB Connector: SMA (female)		
RF-Output Characteristics:	Impedance: 50 Ω Return Loss: >18 dB 1 dB Compression Point: >10 dBm Output Muting: <-75 dBc (by command or sense input or by alarm condition) Connectors: SMA (female)		
Transfer Characteristics:	Max Conversion Gain: 35 dB ± 2 dB 20 dB ± 2 dB (Option LG) Attenuation range: 0...20 dB, 0.1 dB steps Gain Variation over Temp.: ± 1 dB Gain Flatness over Freq.: ± 1.5 dB over band Gain Flatness over 40 MHz: ± 0.5 dB Image Rejection: > 80 dB Noise Figure: < 15 dB		
Group Delay:	Ripple, Slope: <1 ns peak-peak / 80 MHz		
Spurious Outputs:	Signal related: <-65 dBc Signal independent: <-85 dBm		
Intermodulation (3rd Order):	<-53 dBc (two CW signal input, Δf _{in} : 5 MHz, P _{in} 2 x -33 dBm, P _{out} : 2 x -8 dBm)		
Reference Input:	Frequency: 10 MHz sine wave Level: 5 dBm ± 5 dBm Input: through IF input (standard) through MMCX connector (Option RIN) Phase Noise: 10 Hz: -116 dBc/Hz max 100 Hz: -128 dBc/Hz max 1 kHz: -138 dBc/Hz max 10 kHz: -148 dBc/Hz max 100 kHz: -158 dBc/Hz max 1 MHz: -160 dBc/Hz max		
Monitoring and Control Interface:	Protocol: Multipoint Connection: RS422/RS485 (Option RS232)		
Out of lock indicator:	Open Collector (shorted to ground when unlocked) Automatic muting when unlocked		
Temperature Range:	SMBU: 0°C ... +50°C operational HMBU: -30°C ... +60°C operational -46°C ... +73°C storage		
Relative Humidity:	<95 % non condensing, MIL-STD-202F		
Power Input:	12...24 V DC through IF input or external connector		
Power Consumption:	6 W (single band)		
Dimension and Weight:	Single-Band: 100 x 17 x 140 mm ³ (WxHxD), approx. 400 g Dual-Band: 100 x 34 x 140 mm ³ (WxHxD), approx. 800 g Triple-Band: 100 x 51 x 140 mm ³ (WxHxD), approx. 1200 g		
Low Pressure/Altitude:	50,000 feet max., MIL-STD-810E		
Shock/Vibration:	MIL-STD-202F		

Specifications are subject to change

1) SMBU-OCXO or HMBU-OCXO and RF relays are included

Satellite Block-Upconverter (mini-buc)

Modules

Single / Dual / Triple Band L-Band to C, X, Ku-Band

S-Type (standard version), H-Type (extended temperature range)

Order Information:

**SMBU-[RF Band(s)] or
HMBU [RF Band(s)]**

Possible Options are:

LG (Low Gain)

RIN (Ref input via MMCX Connector instead of IF input)

RS232 (Remote control through RS232 instead of RS422/485)

IDU (mounted in 19" rack housing, no power supply, no local control)

ODU (mounted in outdoor housing, no power supply, no local control)

OD (mounted in outdoor housing, with power supply, no local control)

Examples:

SMBU-CXKu1 (Triple band minibuc, SMBU-OCXO and rf-relay are included)

HMBU-Ku (Single band Ku-Band minibuc, extended temperature)

SMBU-Ku-LG (Single band Ku-Band minibuc, low gain)

Block-Converter Reference Module



10 MHz Reference- and Main-Module for mini-buc S-Type (standard version), H-Type (extended temperature range)

Type:	SMBU-OCXO or HMBU-OCXO	
OCXO Phase Noise	10 Hz 100 Hz 1 kHz 10 kHz 100 kHz 1 MHz	-115 dBc/Hz max. -136 dBc/Hz max. -147 dBc/Hz max. -152 dBc/Hz max. -159 dBc/Hz max. -161 dBc/Hz max.
Reference Output:	Frequency: Level: Connector:	10 MHz 3 dBm \pm 1 dBm SMA
External Reference Input:	Frequency: Level: Connector: Mode:	5 or 10 MHz \pm 0.4 ppm 5 dBm \pm 5 dBm SMA auto
Internal frequency Stability:	$\pm 1 \times 10^{-7}$, 0°C ... 50°C $\pm 2 \times 10^{-8}$, 0°C ... 50°C (after 30 min warm up) $\pm 1.5 \times 10^{-9}$ per day (fixed temperature after 24 h warm up)	
IF-Input Characteristics:	Frequency: Impedance: Return Loss: Connector:	950 MHz...1700 MHz 50 Ω >15 dB SMA (female)
IF-Output Characteristics:	Frequency: Impedance: Return Loss: Connector:	950 MHz...1700 MHz 50 Ω > 15 dB SMA (female)
IF Transfer Characteristics:	Max Loss:	2 dB includes switch for IF-signal
Relay Driver:	Support of two RF relays	
Monitoring and Control Interface:	Protocol: Connection:	Multipoint RS422/RS485 or RS232
Alarm-Output:	Two potential free contacts (DPDT)	
Temperature Range:	SMBU-OCXO: 0°C ... 50°C operational HMBU-OCXO: -30°C ... 60°C operational -46°C ... 73°C storage	
Relative Humidity:	<95 % non condensing, MIL-STD-202F	
Power Input:	12...24 V DC	
Power Consumption:	approx. 5 Watt	
Dimension and Weight:	100 x 20 x 140 mm ³ (WxHxD), approx. 350 g	
Low Pressure/Altitude:	50,000 feet max., MIL-STD-810E	
Shock/Vibration:	MIL-STD-202F	

Specifications are subject to change

Order Information: **SMBU-OCXO or
HMBU-OCXO**

Remote Control Unit Satellite Uplink Power Control Unit



This remote control unit is mainly useful for remote control of outdoor converter units. The unit is powered normally remotely from the outdoor unit. The front panel allows to manually control the configuration of an outdoor converter in a similar way as it is possible for indoor converter units.

Also versions to control more than one converter from the same unit are available (Options Dual and Multi). These units include an internal power supply.

Remote control of the complete setup via RS232, RS485 or IP over Ethernet is possible at this control unit, also alarm relay outputs are provided. For the connection to the outdoor unit or to the remote controlled unit in general, an RS485 connection is used.

As option this unit is also available for standard rack mount converters. In this case the unit includes its own power supply. The option internal power supply can also be used to provide power to controlled units, which do not have any own power supply.

Uplink Power Control

Uplink Power Control is a hardware and software option for the Remote Control Unit.

The Uplink Power Control senses a DC signal from a beacon receiver. If due to additional atmospheric attenuation caused by rain, snow, clouds or fog or also due to antenna misalignment the beacon signal is attenuated, the transmitted signal is increased proportionally until a configurable maximum additional gain is reached or the maximum gain of the upconverter is reached.

The uplink power control has the following interface for the DC signal from the beacon receiver:

- Connector type: DSUB-9, male
- DC voltage range: 0 ... 10 V
- Input for lock signal/alarm signal from the beacon receiver

The following Operational Parameters can be configured:

- Uplink power control on/off
- Maximum gain increase in reference to clear sky gain
- Sampling and update period in seconds
- Ratio between decrease of beacon signal and increase of transmission signal (due to difference of rain attenuation effect for different frequencies)
- Up to 5 DC values for beacon signal strength can be entered as reference points for linear interpolation (characteristic of beacon receiver).
- Clear sky value of DC beacon receiver signal
- Sustain period in seconds (up 3600 seconds) for which the uplink power control keeps the last gain increase value (in case of deep fade conditions where the beacon receiver can lose lock for some period of time).

The following Specifications can be monitored:

- DC signal from beacon receiver
- Calculated attenuation of beacon signal
- Current gain increase of transmission signal (theoretical value only if the uplink power control mode is off)

Remote Control Unit

Satellite Uplink Power Control Unit

Model	RC-CO	RC-CI
	Remote Control for Outdoor Units	Remote Control for Indoor Units
Monitoring and Control Interface:	RS232 or RS422/RS485 (Connectors DSUB09 female) (selectable by customer), IP over Ethernet	
Internal Monitor and Control Interface to controlled unit(s):	Standard: RS422/RS485 Alarm signal DC Supply from ODU 12...24 V Connector DSUB25 male Option PS: RS422/RS485 Alarm signal DC Supply to ODU 24 V Connector DSUB25 female Option Dual/Multi: RS422/RS485 Connector DSUB09 female	RS422/RS485 Connector DSUB09 female
Temperature Range:	-30°C ... 60°C operating (the LCD display is operational: -20°C ... 60°C) -30°C ... 80°C storage	
Relative Humidity:	< 95% non condensing	
User Interface:	LCD, 2 x 40 characters, 4 cursor keys, 2 function keys	
Mains Power Input:	Option PS, Dual, Multi: 100 ... 240 V AC nominal, 90...264 V AC max 50...60 Hz Option PS can supply DC power from remote control to converter unit	100 ... 240 V AC nominal, 90...264 V AC max 50...60 Hz
Mains Power Consumption:	Option PS, Dual, Multi: Typ: 10 VA / 6 W, Max: 55W	Typ: 10 VA / 6 W
Mains Power Input Connector:	IEC C14	
Mains Fuse:	2.0 A time-lag fuse	
Dimension and Weight:	483 x 44 x 270 mm ³ (WxHxD), 1 RU (19") approx. 4 kg	

Specifications are subject to change

Order Information:

**RC-CO-[Options] or
RC-CI-[Options]**

Possible Options are: **UPC** (Uplink power control)
UPC/TS (Uplink power control with temperature sensor)
PS (Power supply on RC-CO)
DUAL (Remote Control for two frequency converters)
MULTI (Remote Control for up to 8 frequency converters)
T (Remote Control for dual channel tracking converters)

Examples:

RC-CO
RC-CI
RC-CO-UPC
RC-CO-PS

Satellite Converter Automatic Level Control (ALC) Filter Amplifier



WORK Microwave delivers as stand-alone unit or optionally within downconverters application specific ALC Filter Amplifiers. The picture above shows a stand-alone unit.

The input of this unit can be connected to the IF output of the downconverter.

The picture below shows a block diagram of the application specific ALC Filter Amplifier. The signal is bandpass filtered on the input as well as on the output. Both bandpass filters are identical.

The pictures on the next page show typical amplitude frequency responses of such filters. The overall filter characteristic of the complete unit results from a series connection of the two identical filters, doubling all attenuation values in dB, which means that e.g. a

stop-band suppression of 50 dB for one filter results in a overall stop-band suppression for the complete unit of about 100 dB (for the same frequency point).

In between these filters a variable gain stage allows adjustment of the signal level. A small portion of the output signal level is coupled to an RMS detector.

A digitally implemented control algorithm using a microprocessor allows to select a specified output level and keeps the output level constant, even if the input signal varies within the allowed level range. The operational parameters of the ALC amplifier can be configured from the front panel processor as well as from remote. Also monitoring of the ALC amplifier is possible from the front panel processor as well as from remote. Besides the main ALC output an ALC Monitor Output is available on the rear panel.

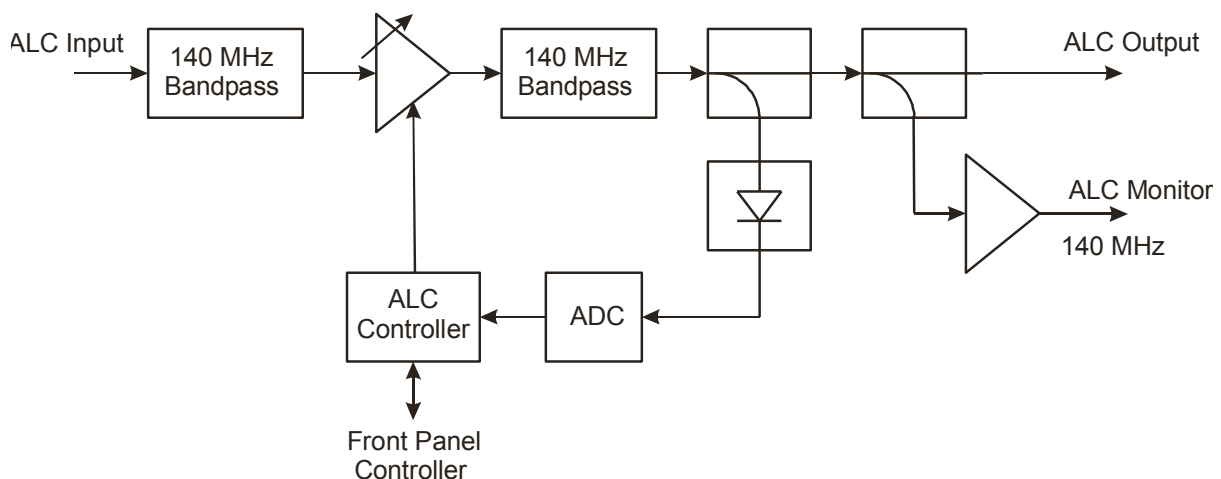

Satellite Converter Automatic Level Control (ALC) Filter Amplifier

Typical Amplitude-Frequency Response of
Response of
one 140 MHz Bandpass Filter with 34 MHz
54 MHz
Bandwidth.

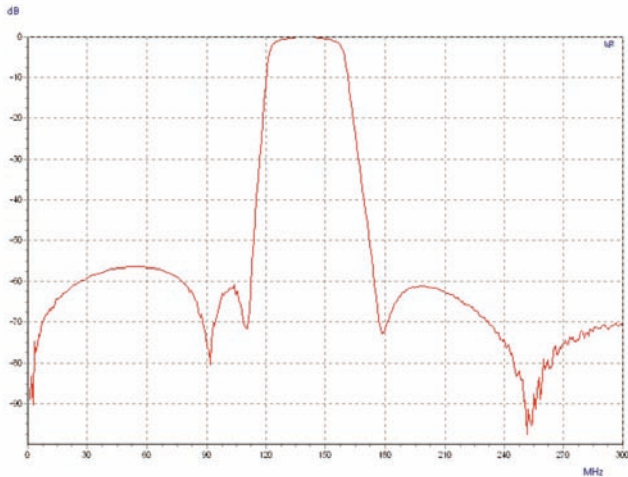

Typical Amplitude-Frequency
one 140 MHz Bandpass Filter with
Bandwidth.

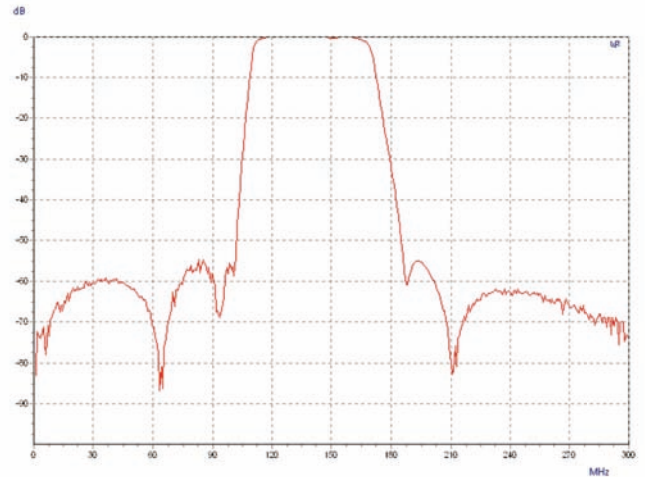

Typical Amplitude-Frequency Response of
Response of
one 140 MHz Bandpass Filter with 75 MHz
110 MHz
Bandwidth.

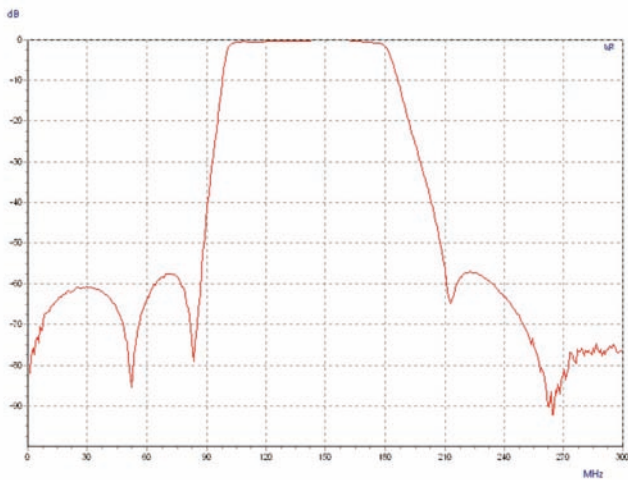

Typical Amplitude-Frequency
one 140 MHz Bandpass Filter with
Bandwidth.

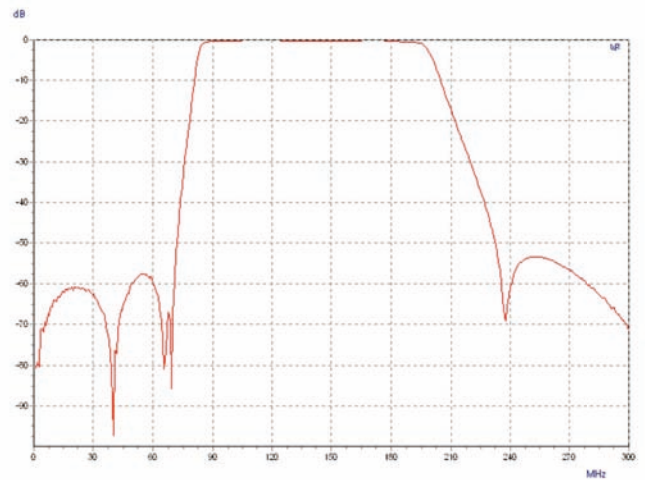

Satellite Converter Automatic Level Control (ALC) Filter Amplifier

IF Input:	Center Frequency: 140 MHz Frequency Range: 80 ... 200 MHz Signal Level: -50 ... -20 dBm Return Loss: >18 dB (within filter passband bandwidth) Connector: SMA female Impedance: 50 Ω
IF Output:	Center Frequency: 140 MHz Bandwidth: 34 MHz or 54 MHz or 75 MHz or 110 MHz Signal Level: -5 dBm ... 10 dBm (adjustable, 0.1 dB step size) Return Loss: >18 dB (within filter passband bandwidth) Connector: SMA female Impedance: 50 Ω
IF Monitor Output:	Signal similar to IF Output Signal Level: 20 dB lower than IF Output Return Loss: >20 dB Connector: SMA female Impedance: 50 Ω
Transfer Characteristics:	Gain: 15 ... 60 dB (automatically or manual adjustable, 0.1 dB step size) Group delay: <0.5 ns / 25 kHz within 54 MHz bandwidth Bandwidth: 54 MHz (3 dB) Frequency Range: 113 ... 167 MHz (3 dB)
Intermodulation (3rd Order):	<-55 dBc, (Pout: 2 x +4 dBm)
ALC Control:	Fast attack for required gain adjustment > configurable value (0.1 ... 5 dB) with configurable time constant up to 1000 s. Gradual adjustment for required gain adjustment < configurable value (0.1 ... 5 dB) with configurable time constant up to 1000 s Control cycle approx. 100 ms. No interruption of the signal during adjustment.
Monitoring and Control Interfaces:	Ethernet/IP (10 or 100 Mbps, auto sensing) RS232 or RS422/RS485 (Connectors DSUB09 female) (configurable)
Alarm Interface:	Two potential free contacts (DPDT, Connector DSUB09 female)
Temperature Range:	-25°C ... 60°C operating the LCD display is operational: -20°C ... 60°C -30°C ... 80°C storage
Relative Humidity:	<95 % non condensing
User Interface:	LCD, 2 x 40 characters, 4 cursor keys, 4 function keys
Mains Power Input:	100 ... 240 V AC nominal, 90...264 V AC max, 50...60 Hz
Mains Power Consumption:	Max: 16 VA / 8 W Typ: 12 VA / 5 W
Mains Power Input Connector:	IEC C14
Mains Fuse:	2.0 A time-lag fuse
Dimension and Weight:	483 x 44 x 270 mm ³ (WxHxD), 1 RU (19") approx. 3 kg

Specifications are subject to change

Order Information:

ALC-[IF Frequency in MHz]-[Filter BW in MHz]

Examples:

ALC-140-34
ALC-140-54
ALC-140-75
ALC-140-110

Redundancy Switch 1:1 Redundancy Controller 1:1 RSCM1



The WORK Microwave Redundancy Switch 1:1 is used for 1:1 redundancy configurations for upconverters, downconverters, modulator-upconverters, transportstream- modulators, demodulators and modems. It includes typically a coaxial signal splitter for the input signal and a coaxial signal switch for the output signal. Optional also an input signal switch instead of the signal splitter is available. For IP modem applications a similar device of type RSC11 is available.

LNAs or even HPAs can be included within the system, as the switch is capable to control external waveguide transfer switches as option. DC power to LNAs can be provided also as option. The switch accepts alarm signals from 2 types of equipment, so that it can be used for redundancy configurations with e.g. a video encoder and a modulator within one chain.

The units can be controlled from the front panel or remotely via RS 232, RS422/485 or IP over Ethernet.

The unit can operate in automatic mode, where an automatic switchover to the stand by unit is performed upon detection of an alarm of the active unit. Also a manual switchover to the standby unit can be initiated. Two power supplies and two AC input connectors guarantee very high availability of the unit.

The 1:1 redundancy is also available in an outdoor version, where the signal splitter and the signal transfer relay is mounted within an outdoor switch box. The control unit is similar to the indoor redundancy controller, but does not include any signal splitters or signals switches the outdoor switch box also includes interfaces for alarms and M&C of outdoor units. A control cable runs from the outdoor switch box to the indoor redundancy controller.

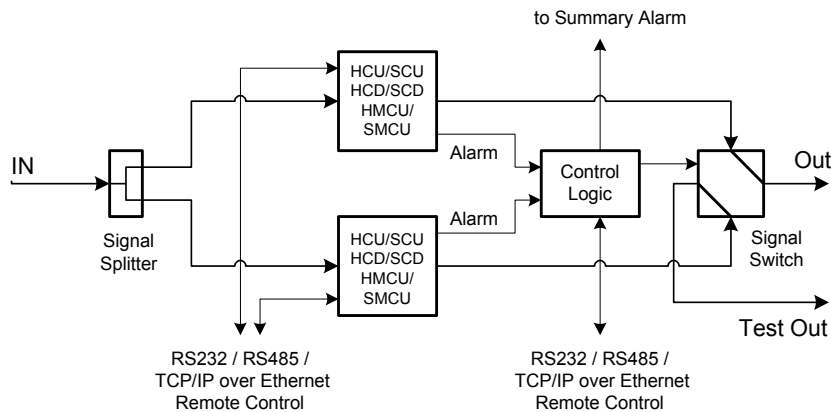

1:1 Redundancy with Signal Splitter

Redundancy Switch 1:1

Model	RSCM1-xx-xx Redundancy Switch 1:1		RSCM1-OD Redundancy Controller 1:1 for outdoor switch box RSB1-xx-xx
Control Interface to Outdoor Switch Box RSB1-xx-xx:	-		Alarm inputs, control outputs (Connector DSUB15 female)
Signal Input Splitter RSCM1-50K-xx	Connector type: Impedance: Power handling: Frequency Range: Insertion loss: Return Loss: Amplitude balance:	3 x SMA female 50 Ω 3 W 6 ... 18 GHz <1.2 dB (above 3dB) >14 dB 0.4 dB	
Signal Input Splitter RSCM1-50C-xx	Connector type: Impedance: Power handling: Frequency Range: Insertion loss: Return Loss: Amplitude balance:	3 x SMA female 50 Ω 3 W 4 ... 8 GHz <1.2 dB (above 3dB) >15 dB 0.4 dB	
Signal Input Splitter RSCM1-50L-xx	Connector type: Impedance: Power handling: Frequency Range: Insertion loss: Return Loss: Amplitude balance:	3 x SMA female 50 Ω 3 W 950 ... 2000 MHz <1.0 dB (above 3dB) >17 dB 0.3 dB	
Signal Input Splitter RSCM1-50V-xx	Connector type: Impedance: Power handling: Frequency Range: Insertion loss: Return Loss: Amplitude balance:	3 x BNC female 50 Ω 1 W 5 ... 300 MHz <1.0 dB (above 3dB) >15 dB 0.4 dB	
Signal Input Splitter RSCM1-75V-xx	Connector type: Impedance: Power handling: Frequency Range: Insertion loss: Return loss: Amplitude balance:	3 x BNC female 75 Ω 1 W 5 ... 300 MHz <1.0 dB (above 3dB) >15 dB 0.4 dB	
Signal Input or Output Transfer Switch RSCM1-50KT-xx RSCM1-xx-50K	Connector type: Impedance: Power handling: Frequency Range: Insertion loss: Isolation: Return loss:	4 x SMA female 50 Ω 1 W (switching) 0 ... 18 GHz <0.1 dB (0 ... 1 GHz) <0.2 dB (1 ... 4 GHz) <0.3 dB (4 ... 8 GHz) <0.4 dB (8 ... 12 GHz) <0.5 dB (12 ... 18 GHz) >85 dB (0 ... 1 GHz) >80 dB (1 ... 4 GHz) >70 dB (4 ... 8 GHz) >65 dB (8 ... 12 GHz) >60 dB (12 ... 18 GHz) >26 dB (0 ... 1 GHz) >21 dB (1 ... 4 GHz) >16 dB (4 ... 8 GHz) >15 dB (8 ... 12 GHz) >14 dB (12 ... 18 GHz)	
Switching:	Manual or Automatic		
Remote M&C Interface:	Protocol:	SNMP	
	Connection:	UDP over Ethernet (10 or 100 Mbps, auto sensing), connector RJ-45	
	Protocol:	HTTP (web browser interface)	
	Connection:	TCP/IP over Ethernet (10 or 100 Mbps, auto sensing), connector RJ-45	
	Protocol:	Multipoint	
	Connection:	RS232 or RS422/RS485 (configurable), connector DSUB09 female or TCP/IP over Ethernet (10 or 100 Mbps, auto sensing), connector RJ-45	
Summary Alarm Interface:	Two potential free contacts (DPDT, Connector DSUB09 female)		
Internal M&C Interface:	RS485 (Connector DSUB09 male)		
Configuration:	16 DIP switches on rear side / serial interface		

Specifications continued next page

Redundancy Switch 1:1 Redundancy Controller 1:1

Specifications continued:

Temperature Range:	-30°C ... 60°C operating -30°C ... 80°C storage
Relative Humidity:	<95 % non condensing
User Interface:	10 LEDs, 4 Function Keys
Mains Power Input:	2 x 100 ... 240 V AC nominal, 90...264 V AC max, 50...60 Hz, Redundant Power Supply, Hot swap
Mains Power Consumption:	Max: 16 VA / 8 W Typ: 10 VA / 5 W
Mains Power Input Connector:	2 x IEC C14
Mains Fuse:	2 x 2 x 2.0 A time-lag fuse
Dimension and Weight:	483 x 44 x 270 mm ³ (WxHxD), 1 RU (19") approx. 3 kg

Specifications are subject to change

Order Information: RSCM1-[Input Splitter or Switch Type]-[Output Switch Type] or RSCM1-OD

Examples:

RSCM1-75V-50K
RSCM1-50KT-50K
RSCM1-OD

Outdoor Redundancy Switch Unit 1:1



Outdoor Redundancy Switch Unit 1:1 RSB1

Outdoor Redundancy Switch Unit 1:1

Model	RSB1-xx-xx Outdoor Switch Unit 1:1	
Signal Input Splitter RSB1-50K-xx	Connector type: Impedance: Power handling: Frequency Range: Insertion loss: Return loss: Amplitude balance:	3 x N female 50 Ω 3 W 6 ... 18 GHz <2.0 dB (above 3dB) > 13 dB 0.4 dB
Signal Input Splitter RSB1-50C-xx	Connector type: Impedance: Power handling: Frequency Range: Insertion loss: Return loss: Amplitude balance:	3 x N female 50 Ω 3 W 4 ... 8 GHz <2.0 dB (above 3dB) >14 dB 0.4 dB
Signal Input Splitter RSB1-50L-xx	Connector type: Impedance: Power handling: Frequency Range: Insertion loss: Return Loss: Amplitude balance:	3 x N female 50 Ω 3 W 950 ... 2000 MHz <2.0 dB (above 3dB) >17 dB 0.3 dB
Signal Input Splitter RSB1-75V-xx	Connector type: Impedance: Power handling: Frequency Range: Insertion loss: Return Loss: Amplitude balance:	3 x N female 75 Ω 1 W 5 ... 300 MHz <1.5 dB (above 3dB) >14 dB 0.4 dB
Signal Input or Output Transfer Switch RSB1-50KT-xx RSB1-xx-50K	Connector type: Impedance: Power handling: Frequency Range: Insertion loss: Isolation: Return Loss	4 x SMA female 50 Ω 1 W (switching) 0 ... 18 GHz <0.5 dB (0 ... 1 GHz) <0.8 dB (1 ... 4 GHz) <1.0 dB (4 ... 8 GHz) <1.2 dB (8 ... 12 GHz) <1.5 dB (12 ... 18 GHz) >85 dB (0 ... 1 GHz) >80 dB (1 ... 4 GHz) >70 dB (4 ... 8 GHz) >65 dB (8 ... 12 GHz) >60 dB (12 ... 18 GHz) >20 dB (0 ... 1 GHz) >17 dB (1 ... 4 GHz) >15 dB (4 ... 8 GHz) >14 dB (8 ... 12 GHz) >12 dB (12 ... 18 GHz)
Switching:	Controlled by RSCM1-OD	
Control Interface to Indoor Control Unit RSCM1-OD:	Alarms, control signals (Connector Type: MIL-C-26482: MS 3120 E 14-26 S)	
Alarm Interface to Converter Units:	2 Interfaces to sense contact closures at alarm outputs of converter units and for internal M&C (RS485) (Connector Type: MIL-C-26482: MS 3120 E 12-19 P)	
Temperature Range:	-30°C ... 60°C operating -30°C ... 80°C storage	
Relative Humidity:	<100 %	
Dimension and Weight:	190 x 100 x 190 mm ³ (WxHxD) approx. 2 kg	
Degree of Protection:	IP 67 (acc. IEC 529)	

Specifications are subject to change

Order Information:

RSB1-[Input Splitter or Switch Type]-[Output Switch Type]

Example:

RSB1-75V-50K

Redundancy Switch 1:1 for IP Modem RSCI1



This version of a WORK Microwave 1:1 Redundancy Switch is specifically designed for IP modems and IP demodulators. Besides this type also a standard 1:1 Redundancy Switch RSCM1 is available, which can be used for modulators, demodulators and modems with ASI transport stream inputs and outputs.

The 1:1 Redundancy Switch RSCI1 includes for the Gigabit Ethernet traffic interfaces a special type of form C (SPDT) Ethernet switch with RJ45 interfaces, to allow switchover from one IP modem or IP demodulator to the redundant one. This operates together with MAC address announcing methods, initiated automatically by the Gigabit Ethernet traffic interfaces: The IP Modulator who detects that a port is getting active (after switchover) sends a broadcast message that the MAC Address has changed. Equipment receiving this message, typically the next router, needs to react to this message and update its ARP resolution table. This is in IPv4 an extension to RFC 826 and is called Gratuitous ARP. For IPv6 it is defined by RFC 4861, clause 7.2.6 and is called Unsolicited Neighbor Advertisement. The downtime after switchover is approximately less than 5 sec, typically only 2-3 sec and depends mainly on the Ethernet auto negotiation time.

Both IP modems or IP demodulators need to be configured in the same way, have different MAC Addresses, but the same IP Address.

For the RF transmit signal a transfer relay is included. For the RF receive signal also a transfer relay or preferably a signal splitter is available, which can be mounted externally to the unit. For L-Band receive signals also a special signal splitter with integrated switch is available, which allows to provide DC and a 22 kHz tone signal always from the active unit to the LNB.

The 1:1 Redundancy Switch accepts alarm signals from the two IP devices. The unit can operate in automatic mode, where an automatic switchover to the stand by unit is performed upon detection of an alarm of the active unit.

For configurations including a splitter on the receive signal side, where both IP devices can receive the RF signal, also monitoring of the receive conditions of both units is implemented. A switchover is performed in case that, with automatic mode enabled, the active unit indicates a non consistent receive problem compared to the standby unit.

Also a manual switchover to the standby unit can be initiated.

The units can be controlled from the front panel or remotely via RS 232, RS422/485 or Ethernet. Two power supplies and two AC input connectors guarantee very high availability of the unit.

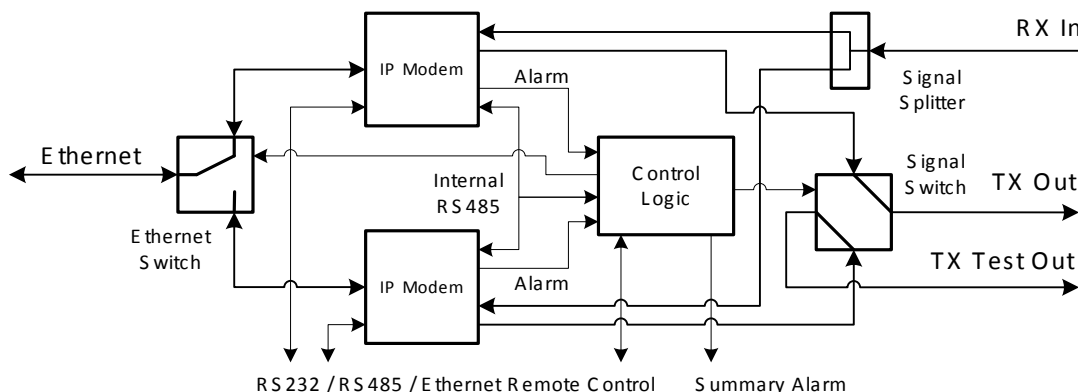

Redundancy Switch 1:1 for IP Modem RSCI1

Model	Item	
RSCI1-0-xx	-	no internal signal splitter or switch is included
RSCI1-50K-xx or RSCI1-50K	Internal Signal Transfer Switch	Connector type: 4 x SMA female Impedance: 50 Ω Power handling: 1 W (switching) Frequency Range: 0 ... 18 GHz Insertion loss: <0.1 dB (0 ... 1 GHz) <0.2 dB (1 ... 4 GHz) <0.3 dB (4 ... 8 GHz) <0.4 dB (8 ... 12 GHz) <0.5 dB (12 ... 18 GHz) Isolation: >85 dB (0 ... 1 GHz) >80 dB (1 ... 4 GHz) >70 dB (4 ... 8 GHz) >65 dB (8 ... 12 GHz) >60 dB (12 ... 18 GHz) Return loss: >26 dB (0 ... 1 GHz) >21 dB (1 ... 4 GHz) >16 dB (4 ... 8 GHz) >15 dB (8 ... 12 GHz) >14 dB (12 ... 18 GHz)
RSCI1-xx	-	no external signal splitter or switch is included
RSCI1-xx-75LD	External Signal Splitter (including diodes for DC)	Connector type: 3 x F female Impedance: 75 Ω Power handling: 100 mW Frequency Range: 500 ... 2400 MHz Insertion loss: 5.0 ... 6.2 dB Return Loss: >20 dB DC Path: max 30 V, 1 A, diode decoupling
RSCI1-xx-75LR	External Signal Splitter (including DC relay switch)	Connector type: 3 x F female Impedance: 75 Ω Power handling: 100 mW Frequency Range: 500 ... 2400 MHz Insertion loss: 5.0 ... 6.2 dB Return Loss: >20 dB DC Path: max 30 V, 500 mA Form C (SPDT) relay
RSCI1-xx-50V	External Signal Splitter	Connector type: 3 x BNC female Impedance: 50 Ω Power handling: 1 W Frequency Range: 5 ... 300 MHz Insertion loss: 3.0 ... 4.0 dB Return Loss: >15 dB Amplitude balance: 0.4 dB
RSCI1-xx-75V	External Signal Splitter	Connector type: 3 x BNC female Impedance: 75 Ω Power handling: 1 W Frequency Range: 5 ... 300 MHz Insertion loss: 3.0 ... 4.0 dB Return loss: >15 dB Amplitude balance: 0.4 dB
RSCI1-xx-50KT	External Signal Transfer Switch	Connector type: 4 x SMA female Impedance: 50 Ω Power handling: 1 W (switching) Frequency Range: 0 ... 18 GHz Insertion loss: <0.1 dB (0 ... 1 GHz) <0.2 dB (1 ... 4 GHz) <0.3 dB (4 ... 8 GHz) <0.4 dB (8 ... 12 GHz) <0.5 dB (12 ... 18 GHz) Isolation: >85 dB (0 ... 1 GHz) >80 dB (1 ... 4 GHz) >70 dB (4 ... 8 GHz) >65 dB (8 ... 12 GHz) >60 dB (12 ... 18 GHz) Return loss: >26 dB (0 ... 1 GHz) >21 dB (1 ... 4 GHz) >16 dB (4 ... 8 GHz) >15 dB (8 ... 12 GHz) >14 dB (12 ... 18 GHz)

Specifications continued next page

Redundancy Switch 1:1 for IP Modem RSCI1

Specifications continued:

Ethernet Hardware Switch	Connector: Type:	3 x RJ45 10/100/1000 Mbps
	MAC Address announcing scheme, initiated by IP traffic ports of IP devices after switchover:	IPv4: according to extension of RFC 826, Gratuitous ARP IPv6: according to RFC 4861, clause 7.2.6, Unsolicited Neighbor Advertisement
Switching:	Manual or Automatic	
Remote M&C Interface:	Protocol: Connection:	SNMP UDP over Ethernet (10/100 Mbps, auto sensing), IPv4, connector RJ-45
	Protocol: Connection:	HTTP (web browser interface) TCP/IP over Ethernet (10/100 Mbps, auto sensing), IPv4, connector RJ-45
	Protocol: Connection:	Multipoint RS232 or RS422/RS485 (configurable), connector DSUB09 female or TCP/IP over Ethernet (10/100 Mbps, auto sensing), IPv4, connector RJ-45
Summary Alarm Interface:	Two potential free contacts (DPDT, Connector DSUB09 female)	
Internal M&C Interface:	RS485 (Connector DSUB09 male)	
Configuration:	16 DIP switches on rear side / serial interface	
Temperature Range:	-30°C ... 60°C operating -30°C ... 80°C storage	
Relative Humidity:	<95 % non condensing	
User Interface:	10 LEDs, 4 Function Keys	
Mains Power Input:	2 x 100 ... 240 V AC nominal, 90...264 V AC max, 50...60 Hz, Redundant Power Supply, Hot swap	
Mains Power Consumption:	Max: 16 VA / 8 W Typ: 10 VA / 5 W	
Mains Power Input Connector:	2 x IEC C14	
Mains Fuse:	2 x 2 x 2.0 A time-lag fuse	
Dimension and Weight:	483 x 44 x 270 mm ³ (WxHxD), 1 RU (19") approx. 3 kg	

Specifications are subject to change

Order Information:

RSCI1-[internal RF Switch Type] -[external RF Splitter or Switch Type]

Examples:

RSCI1-50K-75LD

RSCI1-50K-75LR

RSCI1-50K-50KT

Redundancy Switch N:1 RSCM



The WORK Microwave Redundancy Switch System N:1 can be configured for redundancy configurations with maximum 8 main units and one spare unit. The redundancy system can be used for upconverters, downconverters, modulators, modulator-upconverters, LNAs and even HPAs can optionally be protected. The core of the solution is a highly flexible control unit. The required coaxial transfer switches, waveguide transfer switches or signal splitters are mounted on separate panels or within an outdoor housing. At rack mount redundancy systems switching panels can be added in a modular way to the system if the number of required channels increases over time. Also DC power to LNAs can be provided, if required.

The switching system can be set in automatic mode, where an automatic switchover to the spare unit is performed upon detection of an alarm of the main unit. Also a manual switchover to the spare unit and back can be initiated.

Two power supplies and two AC input connectors within the controller unit guarantee very high availability.

The Redundancy Switch System is also available with integrated Uplink Power Control (Option UPC). For functional details see separate datasheet for Uplink Power Control Unit.

The system can be configured from the front panel of the controller or remotely via RS232, RS422/485 or TCP/IP over Ethernet.

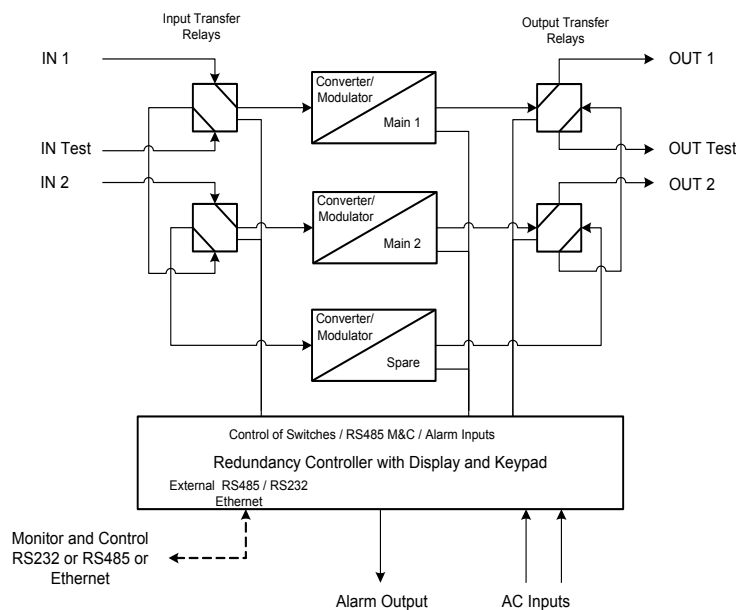

**2:1 Redundancy
Switch System**

Outdoor Redundancy Switch Unit 2:1

The Picture shows an outdoor switching unit of a 2:1 redundant switching system. The switching unit is connected to the control unit, which is installed indoor. Within the outdoor switch unit alarm and status indication via LEDs, manual switchover and easy access to the serial control interfaces of the converter units e.g. is possible. The picture below shows a typical 2:1 configuration with upconverters, built as outdoor solution.

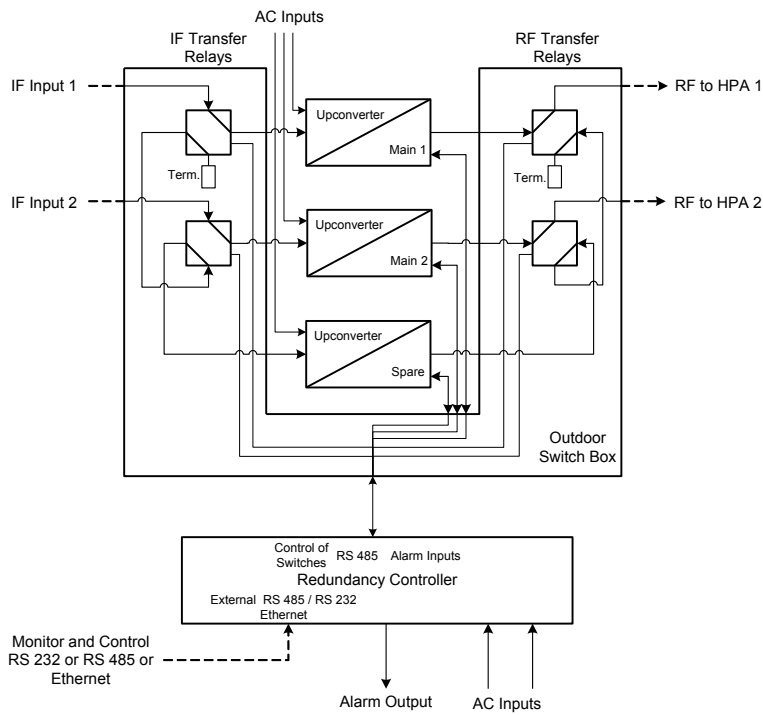

2:1 Redundancy Switch System with Outdoor Switch Unit

Redundancy Switch System (N:1)

Remote M&C Interface:	Protocol: Connection:	SNMP UDP over Ethernet (10 or 100 Mbps, auto sensing), connector RJ-45
	Protocol: Connection:	HTTP (web browser interface) TCP/IP over Ethernet (10 or 100 Mbps, auto sensing), connector RJ-45
	Protocol: Connection:	Multipoint RS232 or RS422/RS485 (configurable), connector DSUB09 female or TCP/IP over Ethernet (10 or 100 Mbps, auto sensing), connector RJ-45
Maximum number of switches per each switch panel:	4 (Indoor switch panel)	
Signal Transfer Switches (Input and/or Output) RSCM-n-xx-50K RSCM-n-50K-xx	Connector type: Impedance: Power handling: Frequency Range: Insertion Loss: Isolation: Return Loss:	4 x SMA female (Indoor switch panel) (N female on IF interfaces, SMA female on RF interfaces of outdoor switch unit) 50 Ω 1 W (switching) 0 ... 18 GHz <0.1 dB (0 ... 1 GHz) <0.2 dB (1 ... 4 GHz) <0.3 dB (4 ... 8 GHz) <0.4 dB (8 ... 12 GHz) <0.5 dB (12 ... 18 GHz) >85 dB (0 ... 1 GHz) >80 dB (1 ... 4 GHz) >70 dB (4 ... 8 GHz) >65 dB (8 ... 12 GHz) >60 dB (12 ... 18 GHz) >26 dB (0 ... 1 GHz) >21 dB (1 ... 4 GHz) >16 dB (4 ... 8 GHz) >15 dB (8 ... 12 GHz) >14 dB (12 ... 18 GHz) (waveguide switches and other transfer switches on request)
Signal Transfer Switches (Input and/or Output) RSCM-n-xx-75L RSCM-n-75L-xx	Connector type: Impedance: Power handling: Frequency Range: Insertion Loss: Isolation: Return Loss:	4 x 1.6/5.6 female (Indoor switch panel) (Adapters to external BNC female connectors are provided) 75 Ω 1 W (switching) 0 ... 2.5 GHz <0.2 dB (0 ... 1 GHz) <0.3 dB (1 ... 2.5 GHz) >80 dB (0 ... 1 GHz) >70 dB (1 ... 2.5 GHz) >20 dB (0 ... 1 GHz) >18 dB (1 ... 2.5 GHz)
Temperature Range:	-30°C ... 60°C operating -25°C ... 60°C operating (for RSCM-n-L75T..) (the LCD display is operational: -20°C ... 60°C) -30°C ... 80°C storage	
Relative Humidity:	<95% non condensing	
User Interface:	LCD, 2 x 40 characters, 4 cursor keys, 2 function keys	
Mains Power Input:	2 x 100 ... 240 V AC nominal, 90...264 V AC max, 50...60 Hz, Redundant Power Supply, Hot swap	
Mains Power Consumption:	Max: 16 VA / 8 W Typ: 10 VA / 5 W	
Mains Power Input Connector:	2 x IEC C14	
Mains Fuse:	2 x 2 x 2.0 A time-lag fuse	
Dimension and Weight of Redundancy Controller:	483 x 44 x 270 mm ³ (WxHxD), 1 RU (19") approx. 4 kg	
Dimension and Weight of Outdoor Redundancy Switch Unit 2:1:	300 x 150 x 400 mm ³ (WxHxD) approx. 7 kg	

Specifications are subject to change

Order Information:

**RSCM-[Number of signal channels]-[Input Switch Type]-[Output Switch Type]-
[Options]**

Possible Options are: **OD** (with outdoor switch unit, available only for two channels)
UPC (Uplink Power control included)
AO (Internal Alarm only connection, without RS485 communication)

Examples:

RSCM-2-50K-50K
RSCM-2-50K-50K-OD
RSCM-8-50K-50K

Outdoor Housings



WORK Microwave provides its proven satellite communication equipment also in different outdoor housings, which can be used under all weather conditions. The units can be operated over a temperature range -30°C to 60°C (-22°F to 140°F). In the non-operating modus they survive temperatures of -50°C to 80°C (-58°F to 176°F) without any damage. Same as the 19" rack mount units, they meet the requirements for modern satellite transmission applications, such as for TV up-link and high-speed data network installations. Because of their rugged construction and low power consumption, they are most suitable for fixed satellite earth stations, satellite news gathering (SNG) vehicles or Fly-Aways.

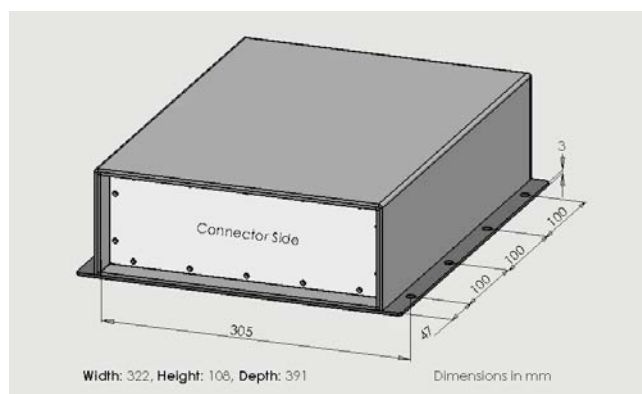

Dimensions of small Outdoor Housing

WORK Microwave outdoor units are best fit to be mounted directly to the antenna. They do not require additional protection against water. The housing provides environmental protection according to IP67 (temporary flooding) when all cables are connected and sealed appropriately. Special environmental protection sleeves for the coaxial connectors allow optimal sealing from the housing to the cable. Additionally the housing should be mounted with the connector side down. Alternatively the connector panel can be in a vertical position.

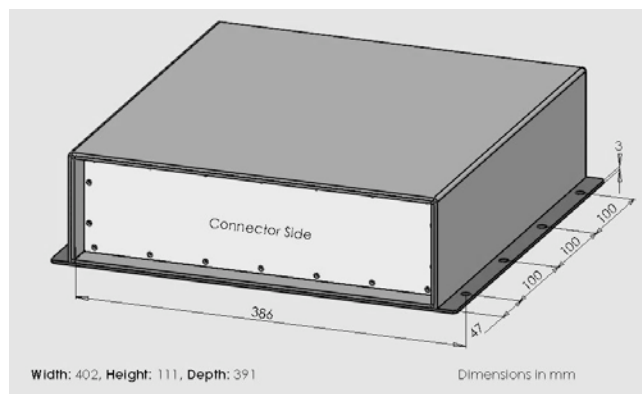

Dimensions of large Outdoor Housing

Monitoring and Control Interface:	RS232 or RS422/RS485 Alarm output: Two potential free contacts (DPDT) 24 V DC output: max 0,3 A 6,5 V DC output: max 0,2 A Mute Input: TTL logic input with internal pull up (Connector type: MIL-C-26482: MS 3120 E 14-19 S)
Temperature Range:	-30°C ... 60°C operating (10 minutes warmup at -30°C)
Relative Humidity:	<100 %
Mains Power Input:	100 ... 240 V AC nominal, 90...264 V AC max, 50...60 Hz
Mains Power Input Connector:	Amphenol C16-1 (3+PE) male
Dimensions:	322 x 108 x 391 mm ³ (WxHxD) (small housing) 402 x 111 x 391 mm ³ (WxHxD) (large housing)
Degree of Protection:	IP 67 (acc. IEC 529)





Raiffeisenstraße 12
83607 Holzkirchen
Germany
Tel. +49 8024 6408 0
Fax +49 8024 6408 40

sales@work-microwave.de
www.work-microwave.de



DIN EN ISO 9001:2000
Zertifikat Nr. 20 100 42000758
www.tuv.at